

Das OCTANORM®-Programm.
OCTANORM® Product Line.



Wandsysteme
Wall Systems



Deckensysteme
Ceiling Systems



Bodensysteme
Floor Systems



Doppelstocksysteme
Two Storey Systems



Lichtsysteme
Lighting Systems



Möbel & Einrichtungssysteme
Furniture and Interior Design Systems



Regalsysteme
Shelving Systems



Displaysysteme
Display Systems



Software & Service
Software & Service

© OCTANORM®-Vertriebs-GmbH, Germany (6777-??/2003)

Display and Presentation Systems

Product Line



OCTANORM®-Vertriebs-GmbH
Raiffeisenstrasse 39
D-70794 Filderstadt
Tel. (+49) 711/77 00 3-0
Fax (+49) 711/77 00 3-53
e-mail: info@octanorm.de
http://www.octanorm.de



OCTANORM®

Expertise with Creative Systems



OCTANORM®

Expertise with Creative Systems



Display and Presentation Systems

A striking message! Displays are supposed to emphasize and to attract attention – in exhibitions, at events, inside and outside shops, or directly at the point of sale. OCTANORM® meets all these requirements with diverse display and presentation systems, optionally with illumination, in a filigree lightweight construction or with stable frame elements. Additionally, you can choose between individual or modular designs for small and large-scale advertising. The display and presentation systems come up to all demands and are made according to OCTANORM®'s well-known philosophy: "best quality of materials, quick handling, easy constructional conceptions and creative designs".



	vario d1 Folding Display	4		Promotion Stand Mobile	26
	vario d2 Framing Display	6		OCTAcounter Counter for Exhibitions and Promotions	28
	vario d2 Portable Version, vario d2 Counter	8		Transparenta Showcases	30
	vario d2 Window Display	10		Design Showcases Square	32
	vario d2 Banner Display	12		Wall and Counter Show- cases Square and Quarter- round Profile	34
	vario d4 Pop Up	14		Literature Rack, Brochure Display	36
	vario d4 Pop Up Fabric	16		Brochure Shelves, Brochure Shelves "Light"	38
	vario d5-Original Promotion Display	18		Display Easel, Hinged Display Frame	40
	vario d5-String Promotion Display	20		Illumination Box Indoor	42
	vario d7 Column Display, vario d7 Counter	22		Clothes Racks, Wall-mounted Clothes Rack	44
	vario d10 Rollup Display	24		Twin-Set Shelving System	46

vario d1

Folding Display

The easy and quick assembly, the variable designing possibilities and the option to create an effective large-scale advertising board are the main characteristics of the folding display vario d1. Four basic modules (from 700 x 1.000 mm up to 2.800 x 2.000 mm) enable the creation of different presentation types – from an individual frame up to an 8-module display. Due to the lateral OCTANORM® system groove, additional connections are possible. The fixing of the panels with the help of magnetic strips can be carried out quickly, neatly and problem-free. With extras such as spots, bags and brochure pockets, vario d1 is a presentation system which can be used in many different ways.



Example type: VA 1680, VA 5036, VA 5032, 3 pcs. VA 5020
Panel recommendation: PVC, 1 mm



VA 6001

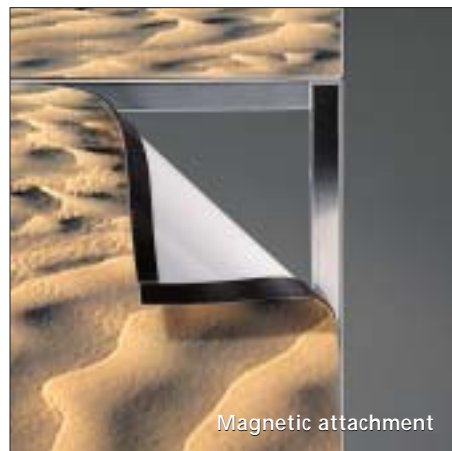

Magnetic attachment

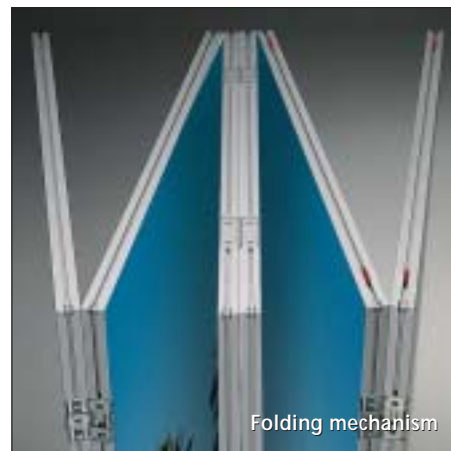

Folding mechanism

Basic modules:

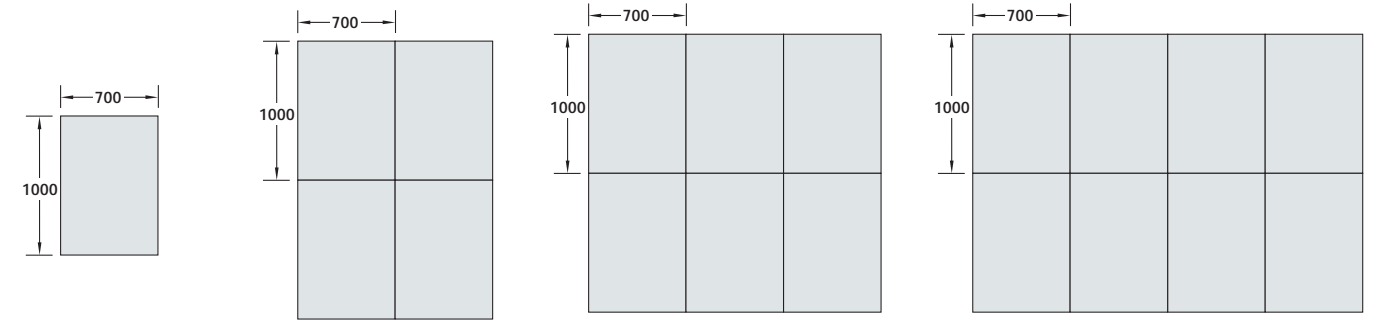

VA 1180 Individual frame

VA 1480 4-module

VA 1680 6-module

VA 1880 8-module

Dimensions correspond to panel size

Accessories:

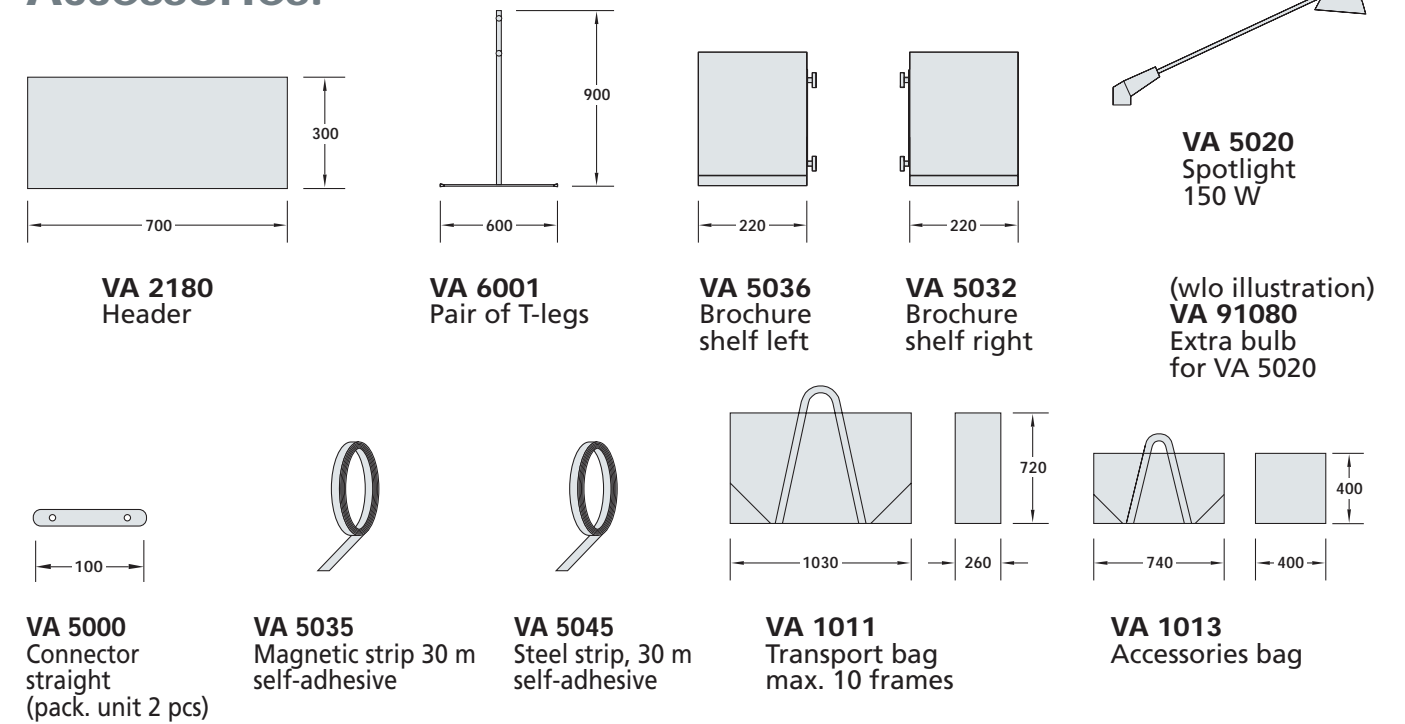

VA 5000 Connector straight (pack. unit 2 pcs)

VA 5035 Magnetic strip 30 m self-adhesive

VA 5045 Steel strip, 30 m self-adhesive

VA 1011 Transport bag max. 10 frames

VA 1013 Accessories bag

VA 5020 Spotlight 150 W

(w/o illustration) VA 91080 Extra bulb for VA 5020

Technical information:

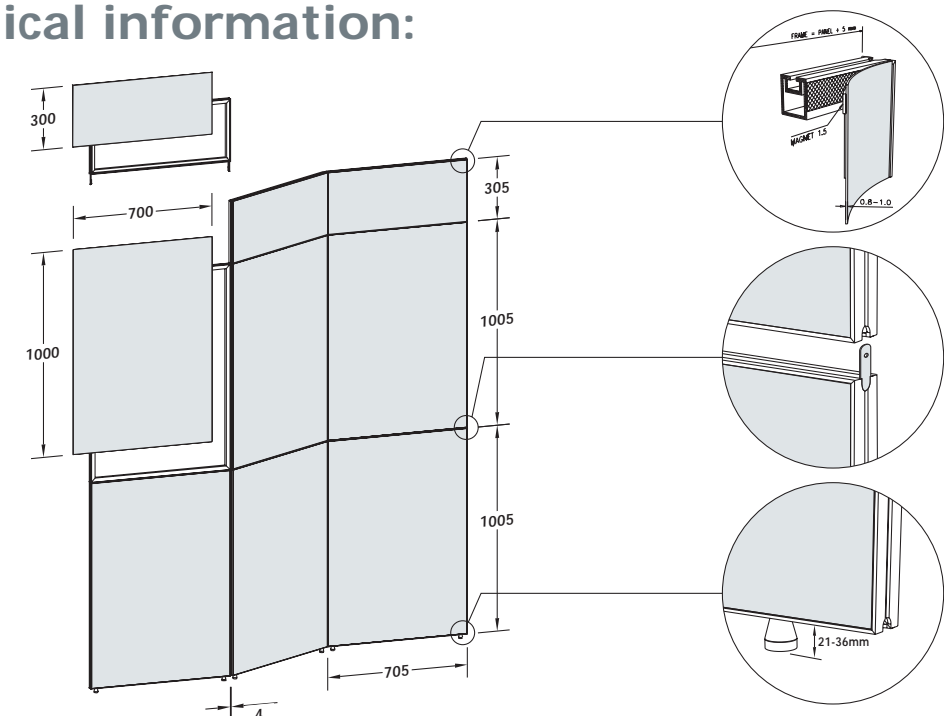

The connector VA 5000 secures the upper and lower part when placed one on top of the other

vario d2-Original

Framing Display

Visually distinctive display with straight or curved frames on which advertising messages can be presented effectively with the help of magnetic strips. Due to the seamless connections, you can fit together as many frames as you like. The lateral OCTANORM® system groove enables connections of many different types. Without any extras, vario d2 looks especially attractive. However, it may also be completed with spots, bags and brochure holders. The technical character of the display system consists of anodized high-quality aluminium profiles. Its low weight and easy assembly make vario d2 an important standard display.



Example type: 3 pcs VA 1275, 2 pcs M 249, 2 pcs M 825, 2 pcs M 1440
4 pcs Z 361, VA 5036, VA 5032, 3 pcs VA 5020
Panel recommendation: from 0.7 mm to 1.0 mm PVC



VA 5020



VA 5036



M 1440



M 1444

Basic modules:

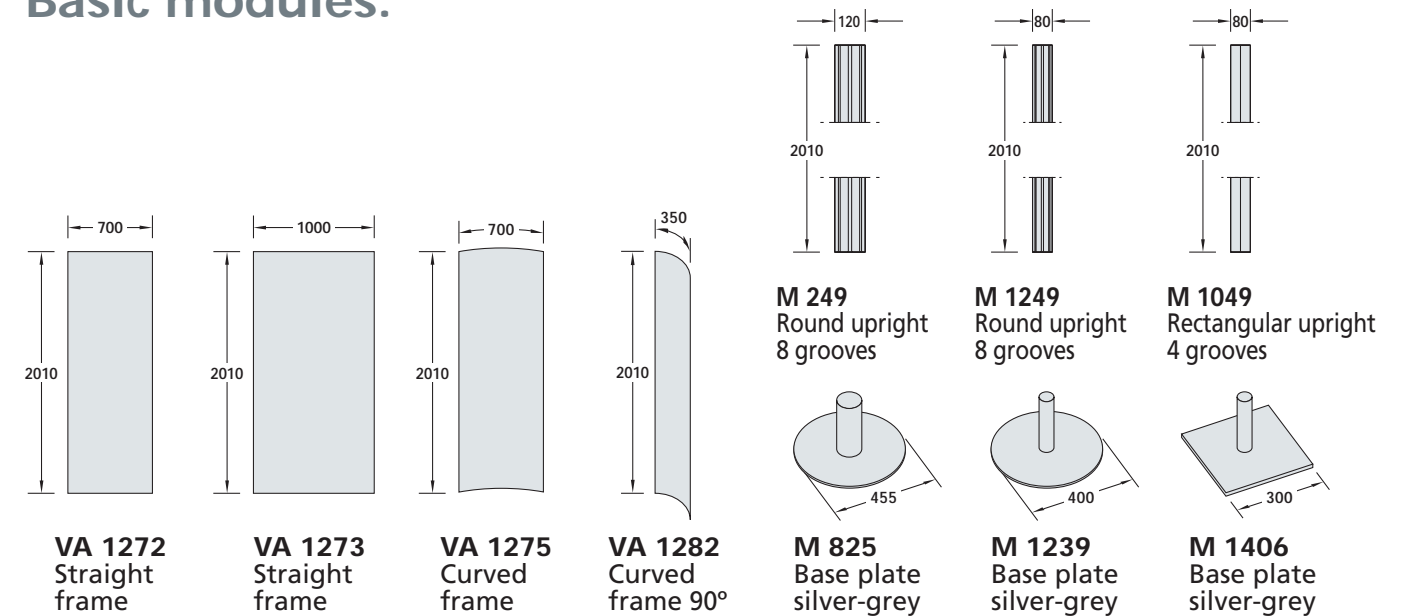

Connecting elements are included, dimensions correspond to panel size

Accessories:

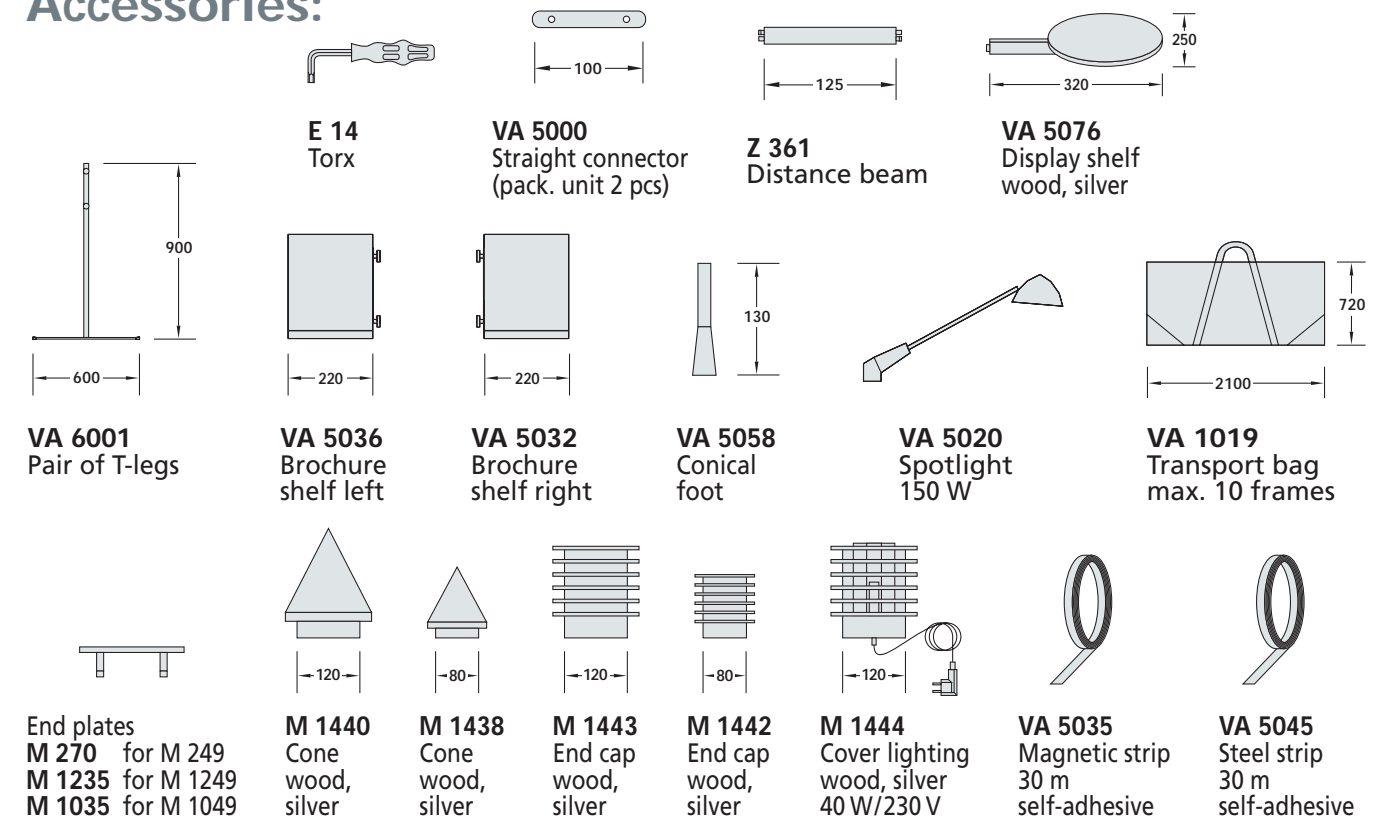

Technical information:

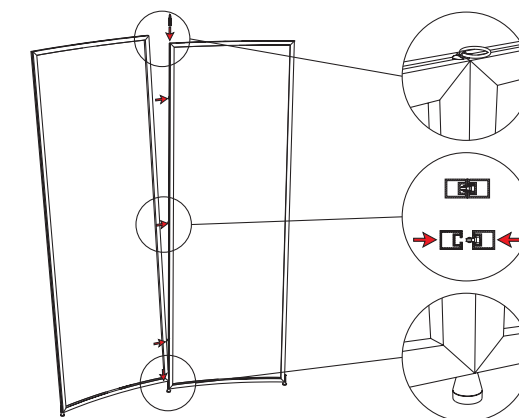

vario d2

Portable Version



The display for trouble-free, professional staging. Visually, technically and with regard to its flexibility it is equivalent to the original vario d2. However, it is quite different in a very essential point: the system supports and grooves are divided. Therefore, it is demountable in very small pieces which even fit into a car. Another advantage: all accessories and supplementary elements contained in the original vario d2 product line may also be used for this portable version. Due to this, it is an ideal complement for large representations which have to be staged with little effort.



Basic modules:

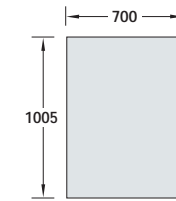

VA 1253
Straight frame

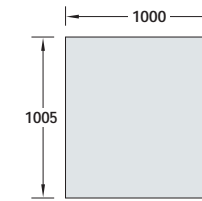

VA 1255
Straight frame

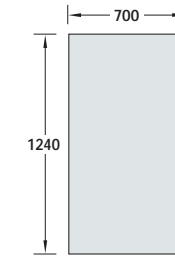

VA 1254
Straight frame

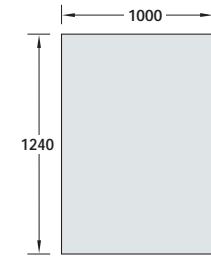

VA 1256
Straight frame

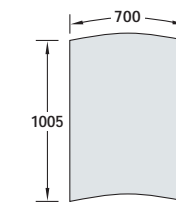

VA 1263
Curved frame

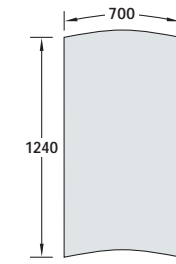

VA 1264
Curved frame

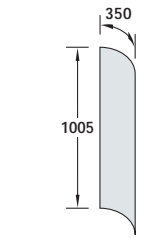

VA 1280
Curved frame 90°

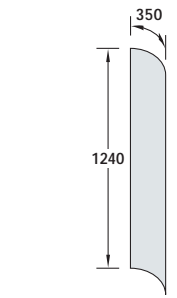

VA 1281
Curved frame 90°

Connecting elements are included, dimensions correspond to panel size

Accessories:

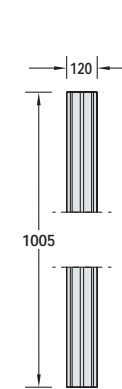

M 247
Round upright
120 mm, 8 grooves

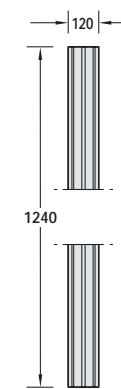

M 248
Round upright
120 mm, 8 grooves

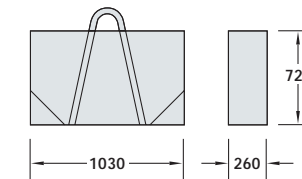

VA 1011
Transport bag

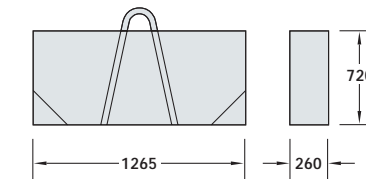

VA 1016
Transport bag

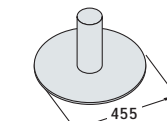

M 825
Base plate
silver-grey

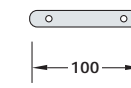

VA 5000
Straight connector
(pack. unit 2 pieces)

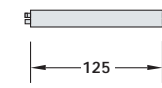

Z 361
Distance beam

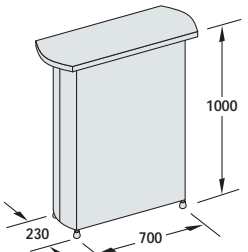

VA 1100
d2-Counter,
incl. transport bag

Further uprights on request

For further accessories out of the vario d2-programme please see pages 7 and 11

Technical information:

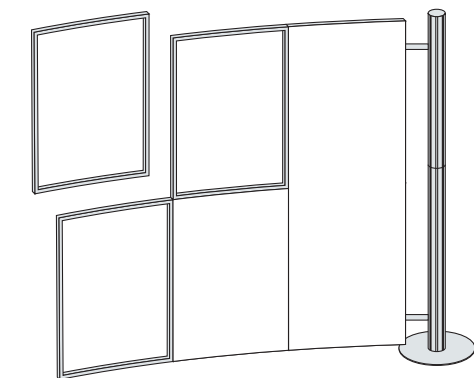
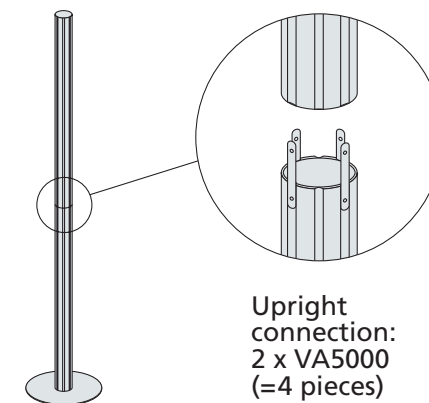

Portable frames on top and side by side

vario d2

Window Display

An amazing assistant for an eye-catching presentation of advertising messages in shop windows or in the salesroom since this display is extremely versatile. With a foot element it may be extended just as you like and with its loops, it can easily be hung from the ceiling. On request, it will be supplied with steel strips on both sides in order to use it as a billboard in salesrooms. And the attachable spot shows important content in a favorable light. Its standard format is A1. Further formats are available on request. The vario d2 shop window display is suitable both for targeted individual actions and for large, striking shop window spaces.



Example type standing: VA 1249, VA 8702, 2 pcs VA 6003
Example type suspended: VA 1249, 2 pcs E 218



Example type: 2 pcs VA 1249
3 pcs VA 6003



Spotlight VA 8702



Ring screw E 218

Basic modules:

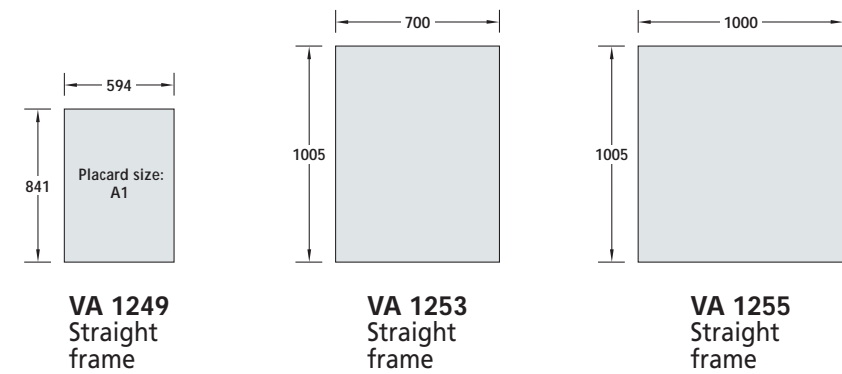

Connecting elements are included, dimensions correspond to panel size

Accessories:

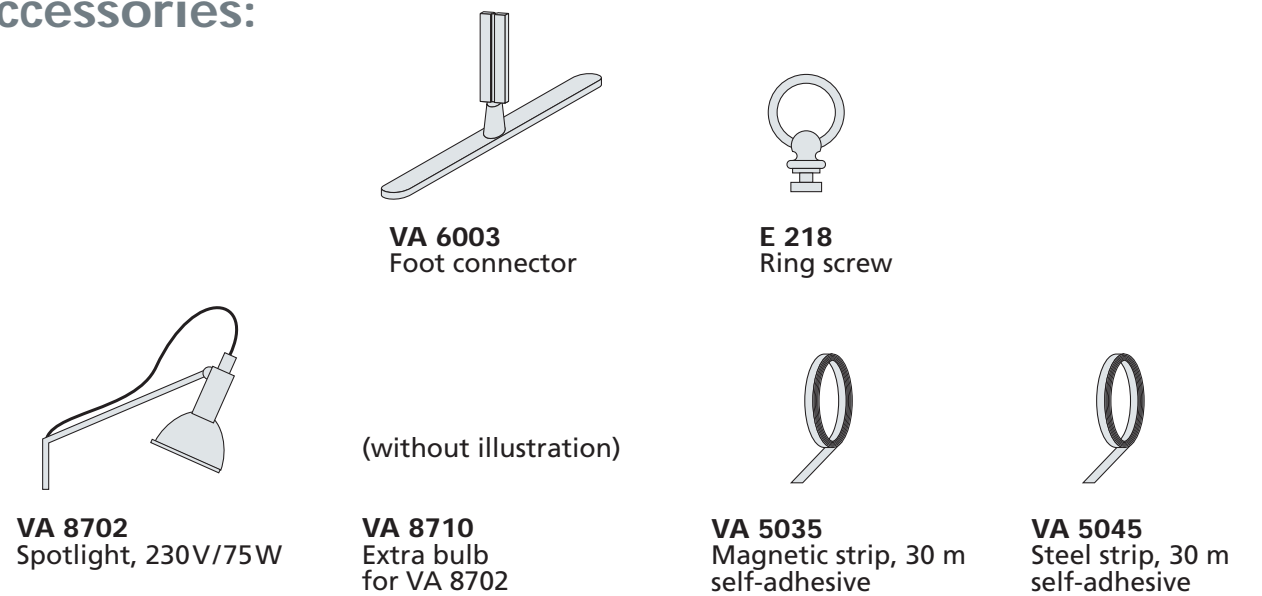

For further accessories out of the vario d2-programme please see pages 7, 9 and 13

Technical information:

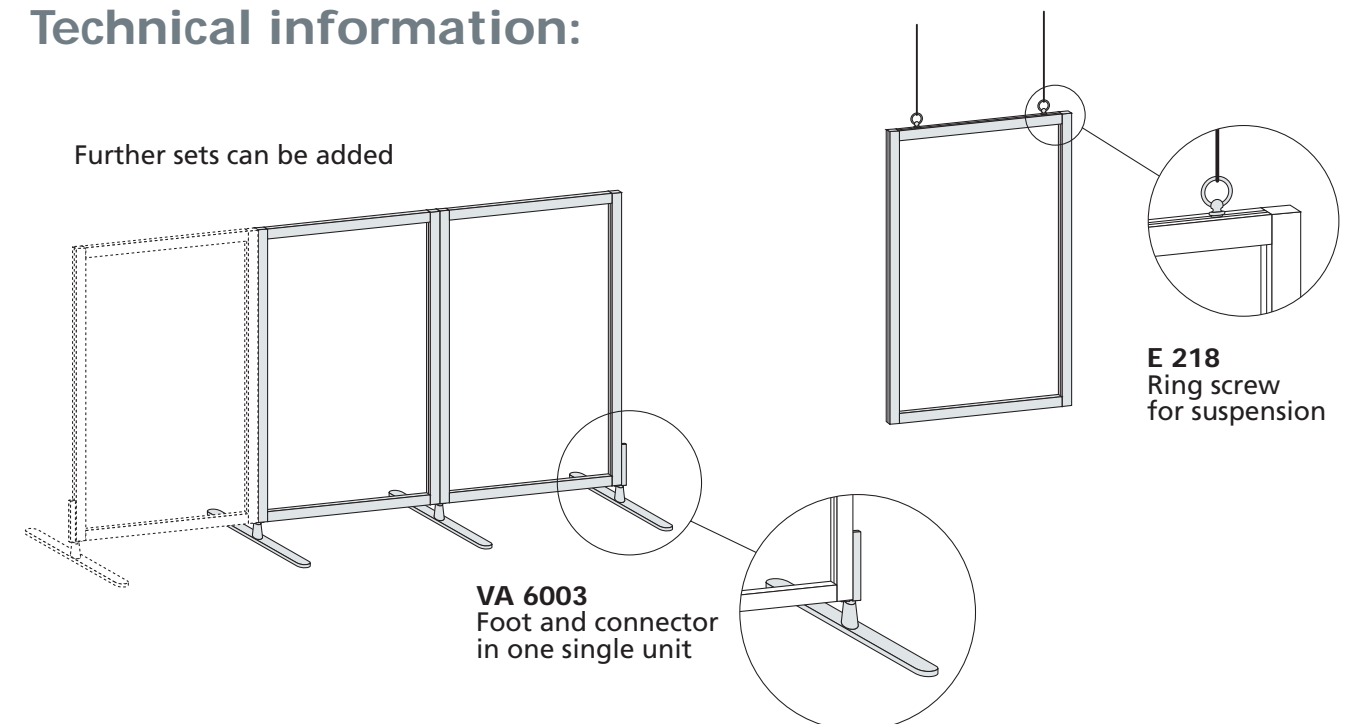

vario d2

Banner Display

The successful trio which converts textile digital printings into an advertising highlight. Base plate, support and grooves are the three system components this attractive display is made of. The principle is quite simple: the grooves are inserted into the hemstitches of the printed fabrics. With the help of the tension jack at the bottom groove, the textile banner is smoothed out. Three versions are available: with a support and a one or two-sided banner or with two supports and a centered banner.



Example type: set M 1350, VA 5032, VA 5036
Panel recommendation: textile banner with hemstitch



Banner set, two-sided M 1352



Tension lock and torx E 14



Connection of upright and beam



Base plate M 1239 and upright M 1249

Basic modules:

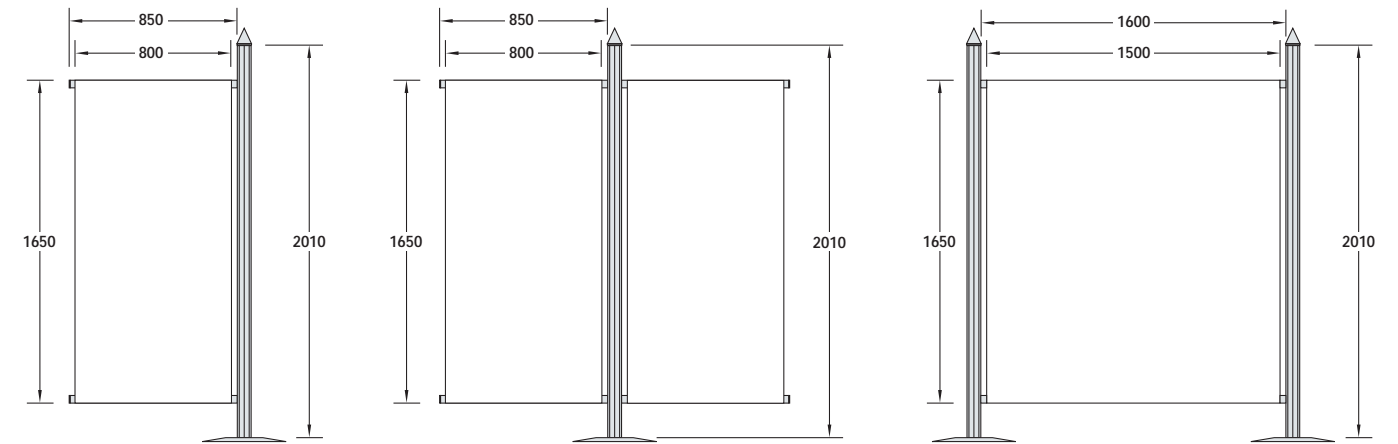

M 1351
Banner set, one-sided
1 upright, 80 mm ø,
2 beams 850 mm long
incl. base plate and cone

M 1352
Banner set, two-sided
1 upright, 80 mm ø,
4 beams 850 mm long
incl. base plate and cone

M 1350
Banner set, center position
2 uprights, 80 mm ø,
2 beams 1600 mm long
incl. base plate and cone

Inside dimensions correspond to banner size

Accessories:

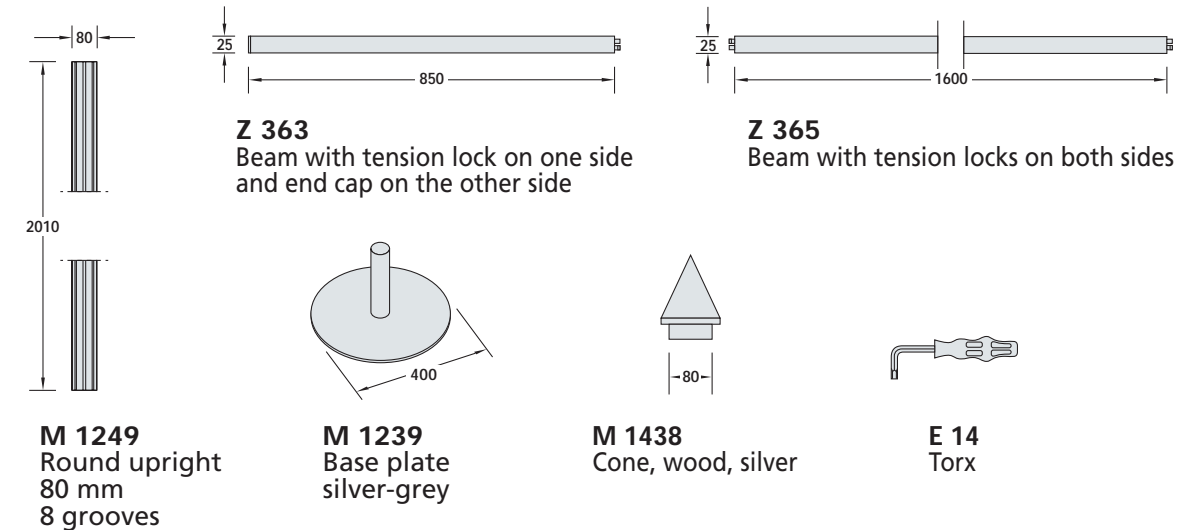

Z 363
Beam with tension lock on one side
and end cap on the other side

Z 365
Beam with tension locks on both sides

M 1249
Round upright
80 mm
8 grooves

M 1239
Base plate
silver-grey

M 1438
Cone, wood, silver

E 14
Torx

For further accessories out of the vario d2-programme please see pages 7, 9 and 11

Technical information:

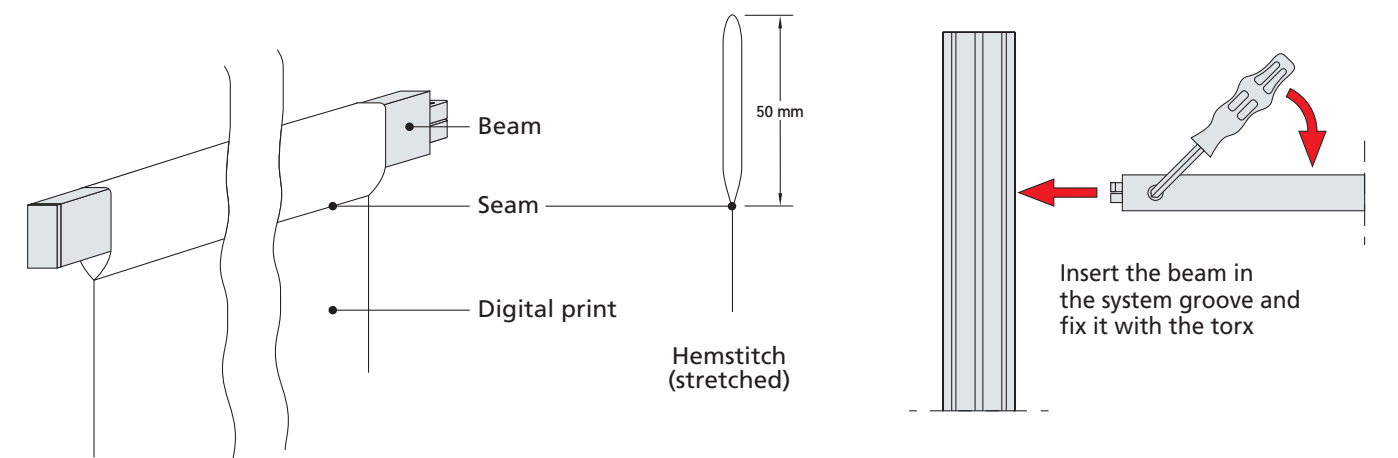

Insert the beam in the system groove and fix it with the torx

vario d4

Pop Up



Example type: VA 4833 P1, 2 pcs VA 5021, VA 8056
Panel recommendation: PVC, 1 mm

When you want to create a fast, persuasive impression in a place where crowds of people meet or pass by, vario d4 is the ultimate solution. Large format text and pictures are displayed simply and ingeniously. Panel sections can be mounted rapidly without unsightly seams. The simple, lightweight construction makes vario d4 perhaps the most powerful support for your messages available anywhere. The display, lighting and pictures are stored separately in the practical transport case, which is easily converted into a counter. The vario d4 is extremely compact when dismantled and requires little storage space.

Basic modules:

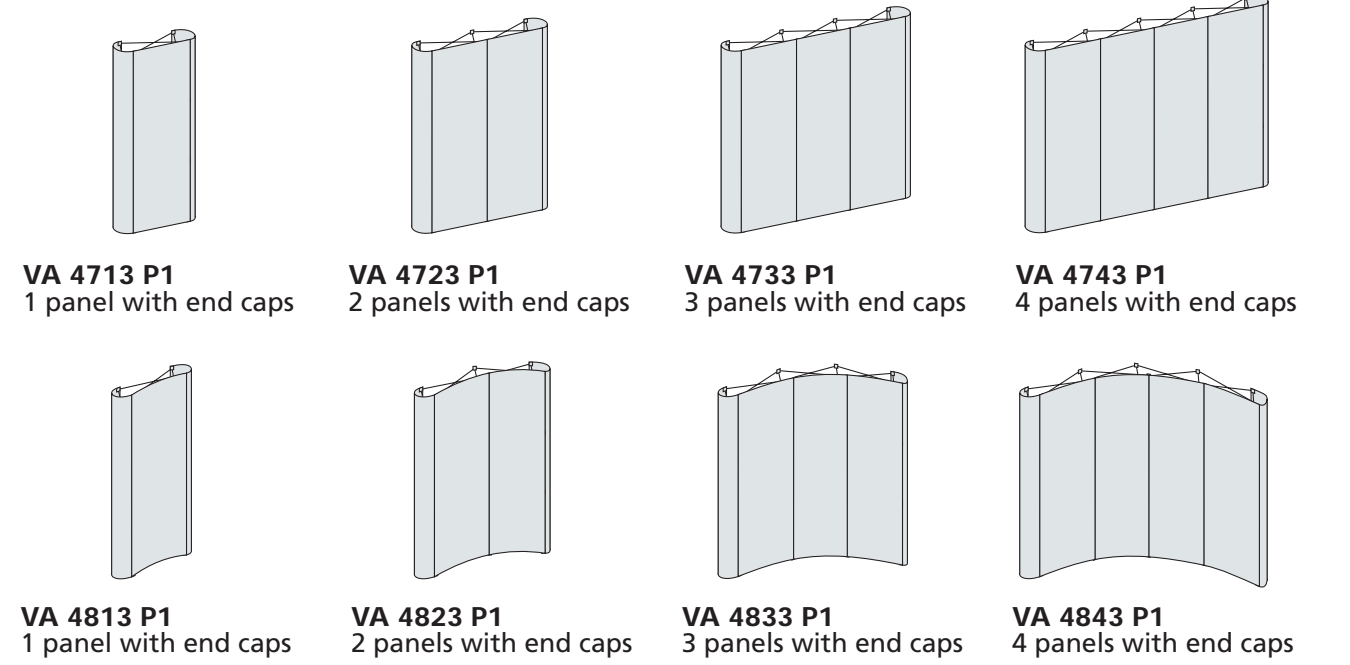

All systems illustrated are supplied excluding graphic panels

Accessories:

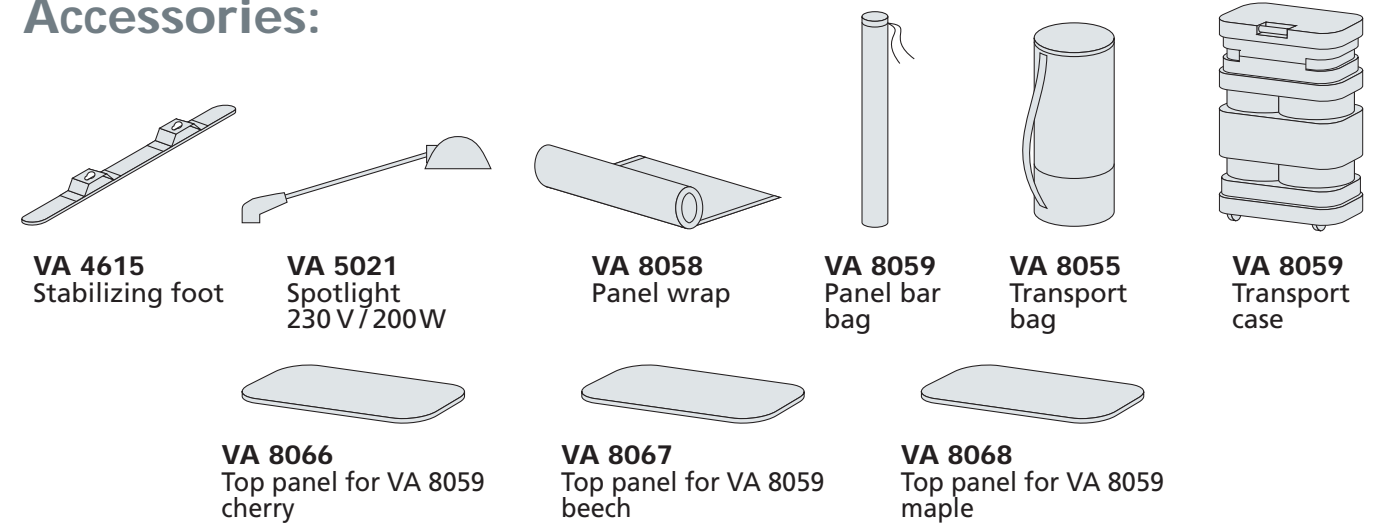

Technical information:

3 panels, curved, with end caps

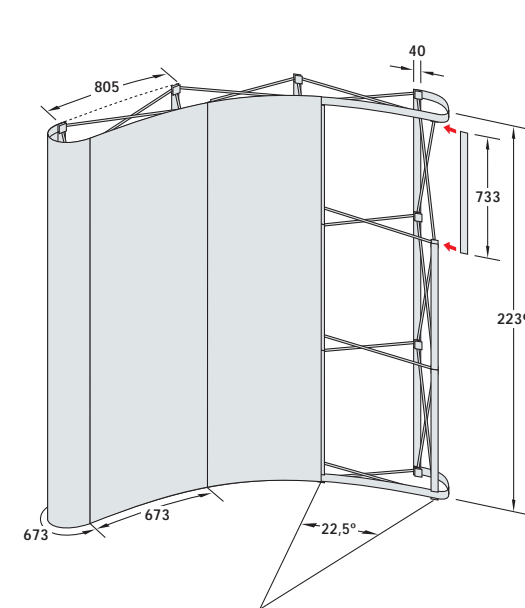

3 panels, straight, with end caps

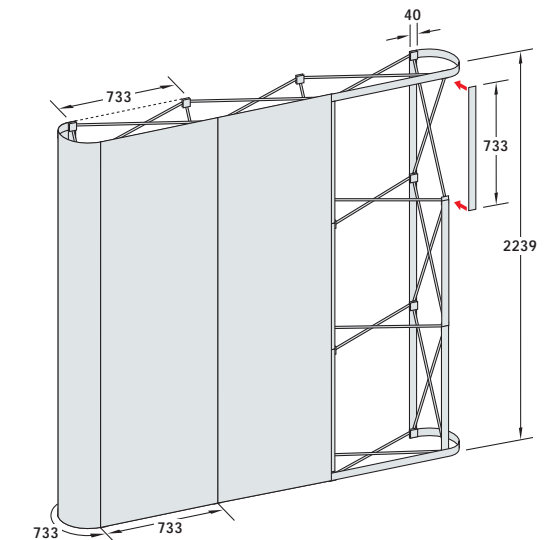

VA 8056 Transport case (2 pcs)



VA 8058 Panel wrap for graphic panel



VA 8065 Transport case

vario d4

Pop Up Fabric

vario d4 creates a solid impression by displaying large-format pictures. The fabric display is a further enhancement of the Pop Up version. The unique advantage of the vario d4 fabric display is that it can be assembled in no time – an indispensable feature when the same message has to be presented at different meeting venues on a tight schedule. The graphics are printed on fabric that stays on the unit even when dismantled. The specially designed fabric allows the large-format graphics to be displayed over and over with no loss of sharpness and a completely smooth surface.



Example type: VA 4933, 2 pcs VA 5021
Panel recommendation: PVC, 1 mm



VA 6001 Transport bag



VA 4615 Stabilizing foot

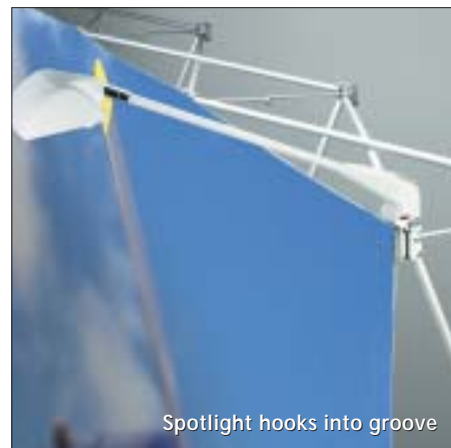

Spotlight hooks into groove

Basic modules:

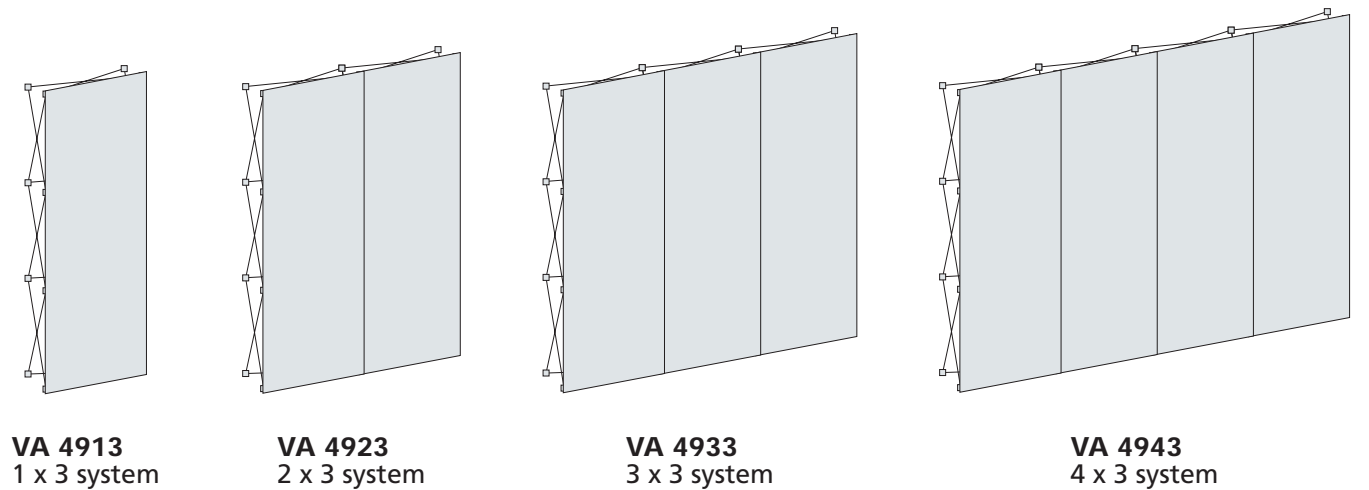

VA 4913
1 x 3 system

VA 4923
2 x 3 system

VA 4933
3 x 3 system

VA 4943
4 x 3 system

All systems illustrated are supplied excluding fabric panels

Accessories:

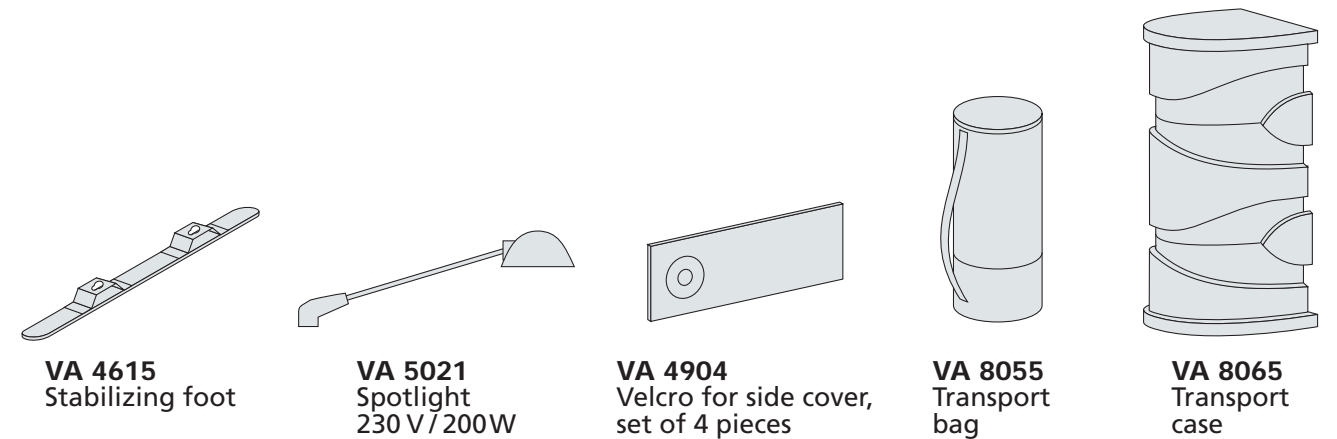

VA 4615
Stabilizing foot

VA 5021
Spotlight
230 V / 200W

VA 4904
Velcro for side cover,
set of 4 pieces

VA 8055
Transport
bag

VA 8065
Transport
case

Technical information:

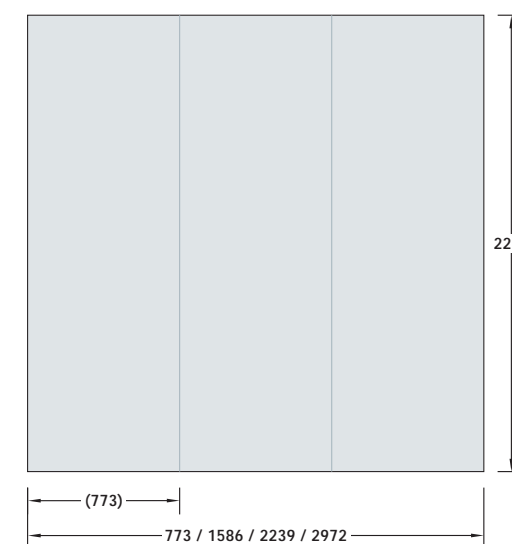

Correct panel size depends on stretchiness of fabric

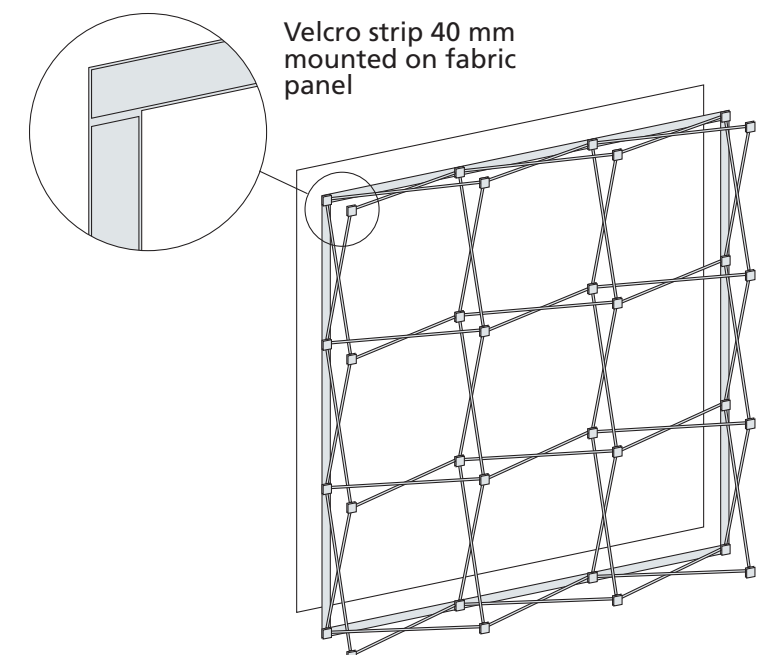

Velcro strip 40 mm mounted on fabric panel

vario d5

Promotion Display



Example type: VA 8500, VA 8700
Panel recommendation: drop paper, max. thickness: 0.25 mm

A real display innovation: vario d5 is simply rolled up in its transport bag which at the same time is the base of the display. The assembly and dismantling are easy tasks and require only a few seconds of time. The stability of the display is achieved by means of a tension rod. The panels of a width of 60 or 80 cm and a thickness from 0.1 up to 0.25 mm can also be placed side by side for large-scale advertising. For attracting specific attention with light, a spot can be fixed at the tension rod.

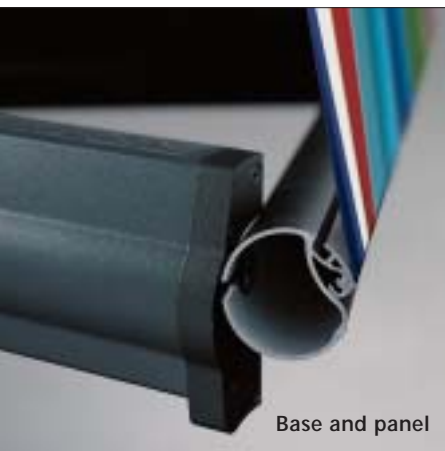

Base and panel



VA 8700 Spot



Clamping profile at the top

Basic modules:

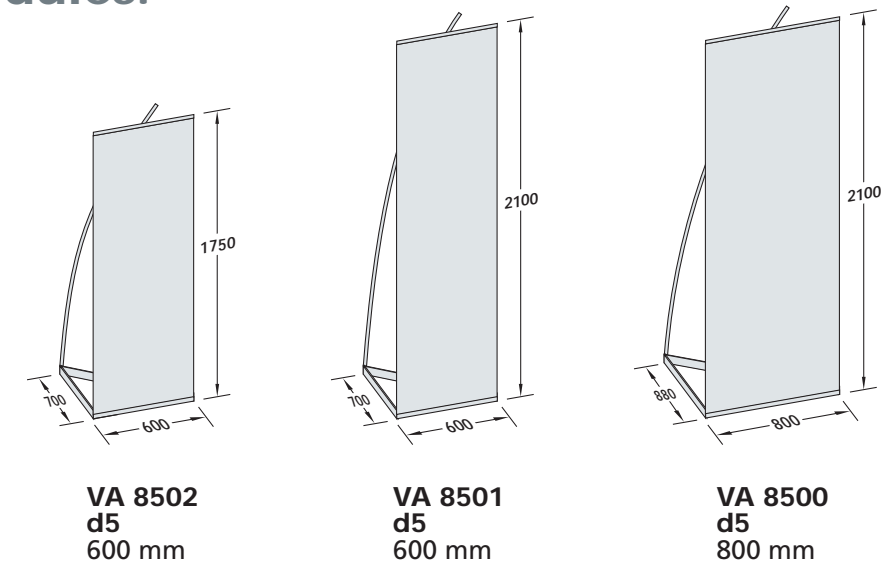

Dimensions according to the panel size

Accessories:

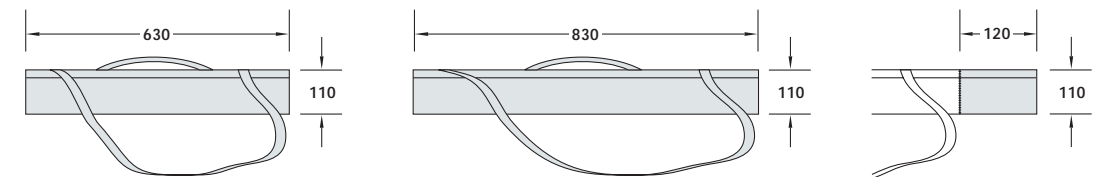

VA 8601
Transport bag
for d5-60 cm

VA 8600
Transport bag
for d5-80 cm

VA 8602
Spot bag
for VA 8700

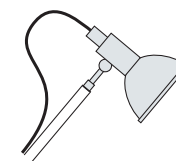

VA 8700
Spotlight
220V/75W

(without illustration)

VA 8710
Extra bulb
for VA 8700



VA 8005 SW
Clamping profile 5 m, black
profile cuts on request



VA 5019
d5 connector

Technical information:

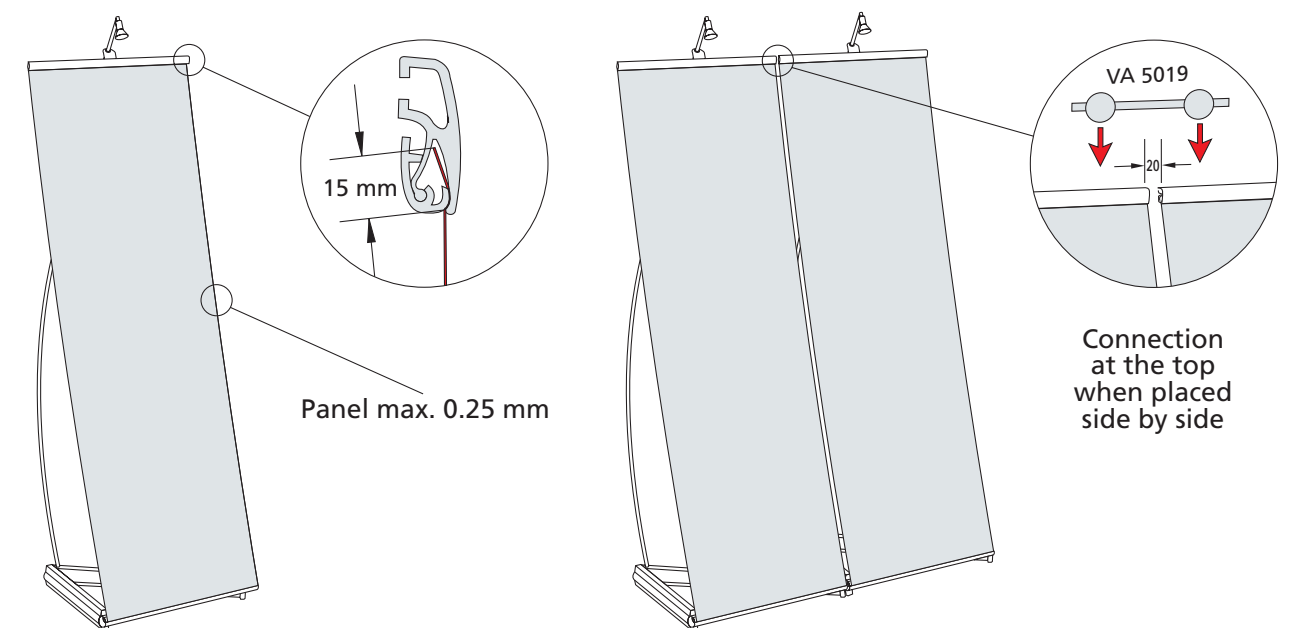

Panel max. 0.25 mm

Connection
at the top
when placed
side by side

vario d5-String Promotion Display

The flexible suspension unit offers almost all the advantages of the original vario d5 with one decisive difference: with just 400 mm depth it is extremely economical on space. The d5-String display is quickly assembled and requires no tools. Banners, boards or posters are fixed with the practical clip profile. d5-String is available in 600, 800 and 1000 mm width. Special widths available on request. Its lightweight and handy dimensions make this display the optimum accessory for "quick-fix" promotions. Attractive professional impact even for small budgets.



Example type: VA 8300, VA 9700
Panel recommendation: Banner, max. thickness 0,25mm



Spotlight VA 9700



Beam with screw
Assembly without tools



Rears, narrow footprint

Basic modules:

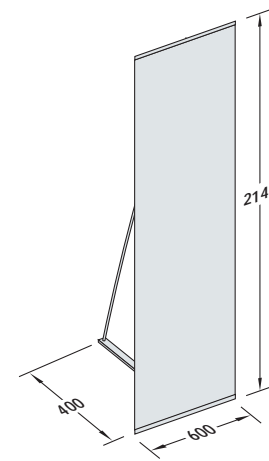

VA 8301
d5-String
600 mm

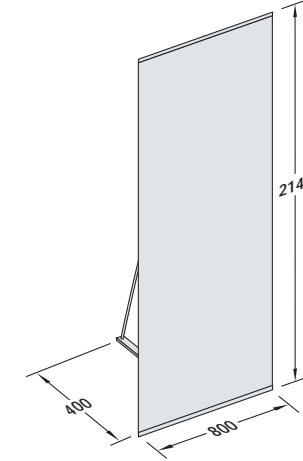

VA 8300
d5-String
800 mm

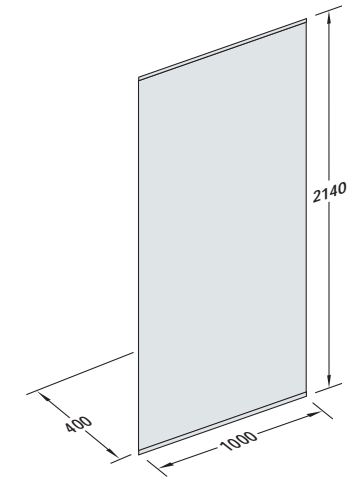

VA 8302
d5-String
1000 mm

Dimensions correspond to panel size

Accessories:

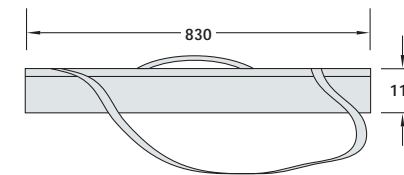

VA 8604
Transport bag
for d5-String, 600 and 800 mm

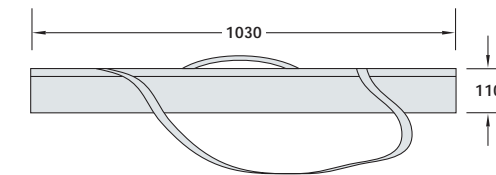

VA 8603
Transport bag
for d5-String, 1000 mm

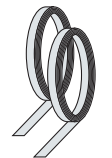

VA 5067
Magnetic strip Set, each 10 m
both sided polarised

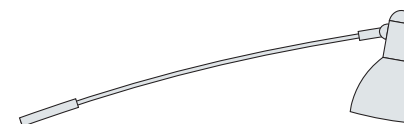

VA 9700
Spotlight, 230V/75W

(without illustration)



VA 8005
Clamping profile 5 m,
silver
profile cuts on request



VA 5019
d5 connector

Technical information:

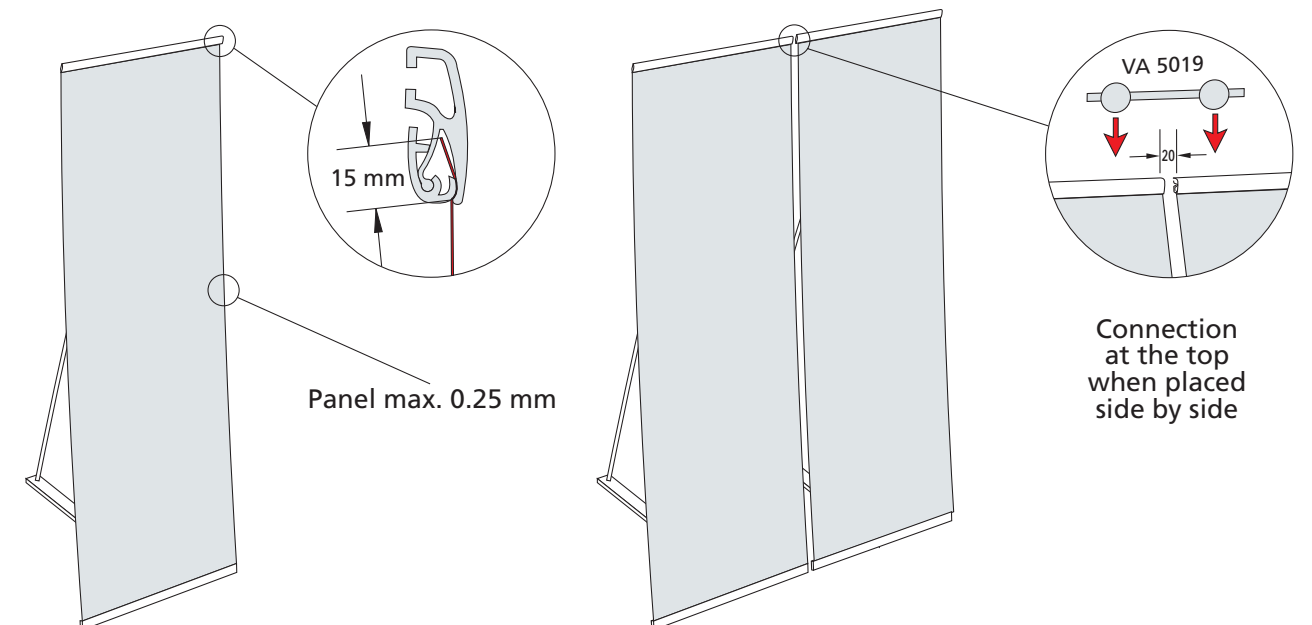

vario d7

Column Display

Impressive presentation with diverse visual effects. The column display vario d7 is available with or without an illumination system operated via a foot switch. The panels made of hard-foam or acrylic glass can be replaced quickly and problem-free with the clip profiles. The upper and lower cover plates fit both sides together to an oval unit. Whatever will be presented in these column displays, it will attract attention – the best pre-condition for success!
The matching counter completes d7 to a promotion set with lighting.



Example type: VA 7500, VA 7700
Panel recommendation: without illumination: Hardfoam panel of max. 2 mm
with illumination: acrylic glass of max. 1.5 mm



VA 7300



VA 7700

Basic modules column display:

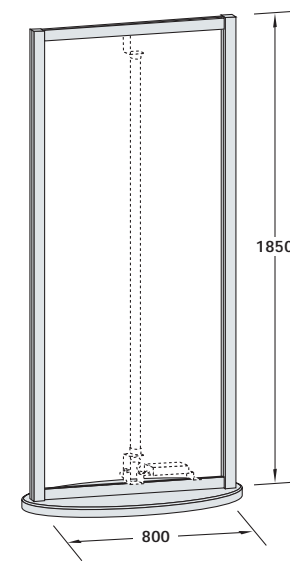

VA 7500
Basic set vario d7
(without panel)

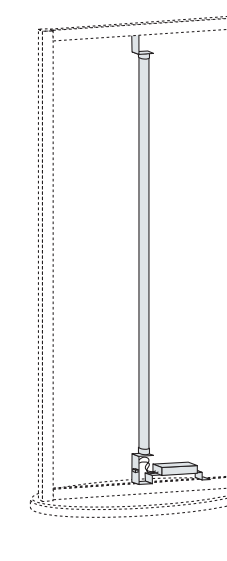

VA 7700
Illumination set
vario d7

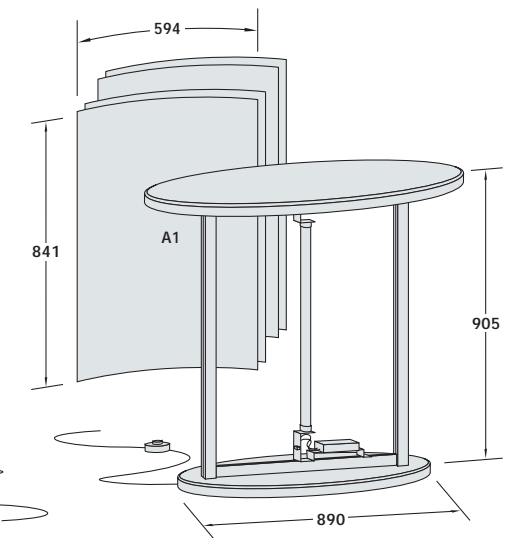

VA 7300
Basic set counter
incl. illumination, 230V/18W,
and 4 panels A1

Accessories:

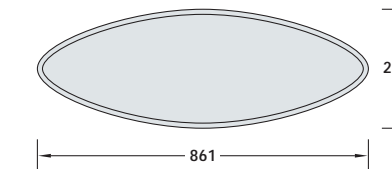

VA 7501
Top cover plate for VA 7500, wood black

Technical information:

Panels are clipped on both sides into the aluminium supports.

Translucent panel with digital print

The printed paper A1 is mounted between support panels on both sides

Transparent panel
Printed paper A1
Translucent panel

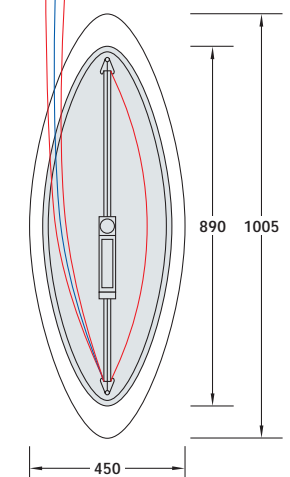
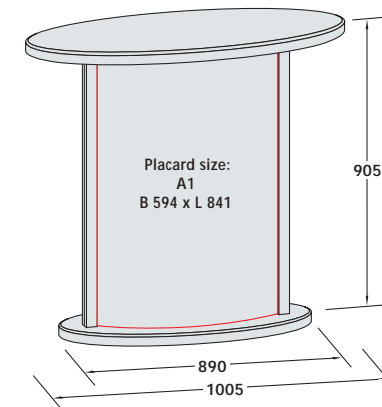
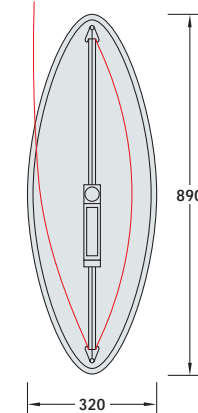
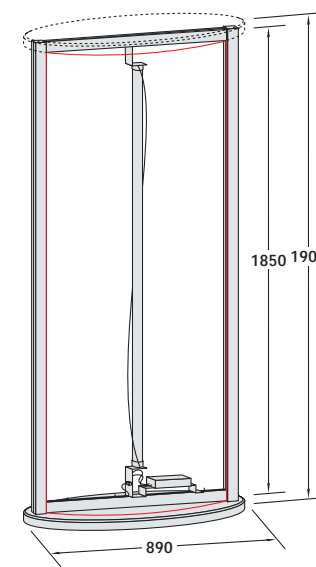

Panel size: B 800 x L 1850

Dimensions according to the overall size

vario d10

Rollup Display

Quick, effective, compact: these are the features a display not afraid of being used in different ways should offer. On the contrary: this display is made for being rolled out of its casing within a few seconds one day here and the next day there. Even the lighting is included in the system and the base provides sufficient space for the spotlight. All this fits into the practical transport bag. By means of connectors, the standard widths 840 and 940 mm can be combined and extended just as you like. A quick medium always ready for use that enables flexible solutions.



Example type: VA 9522, one-sided



Spotlight VA 9701



Assembly within seconds



Fixation and cable guide

Basic modules:

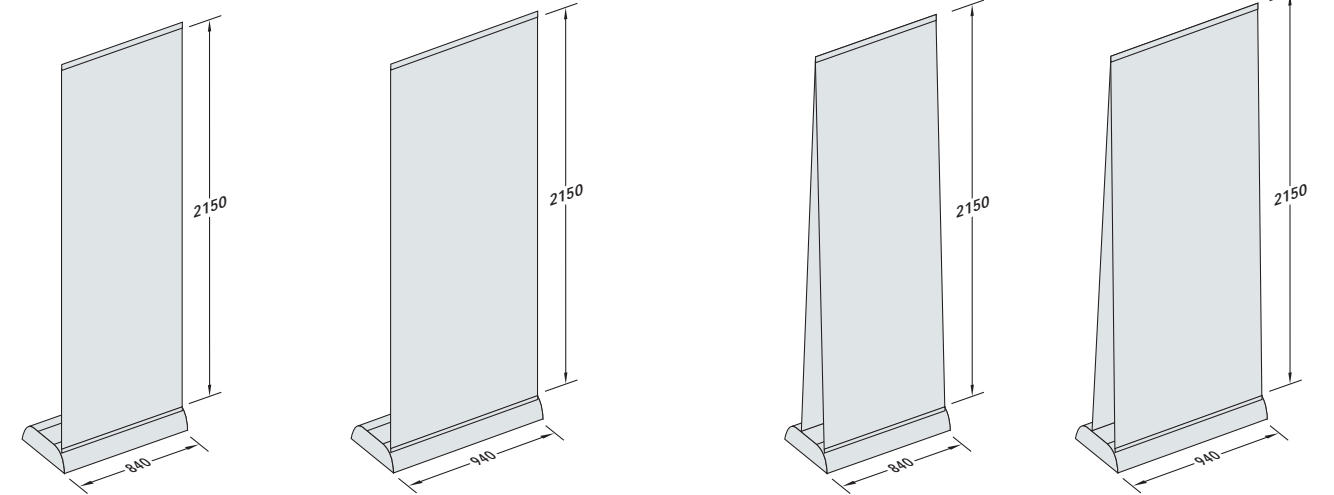

VA 9522
d10, one-sided (front)
840 mm wide

VA 9521
d10, one-sided (front)
940 mm wide

VA 9524
d10, double-sided
840 mm wide

VA 9523
d10, double-sided
940 mm wide

Stretched panel size 2300 mm

Accessories:

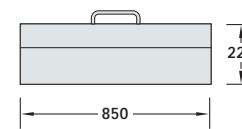

VA 9603
Transport bag
for VA 9522

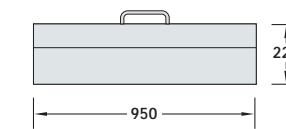

VA 9602
Transport bag
for VA 9521

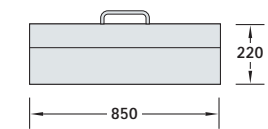

VA 9605
Transport bag
for VA 9524

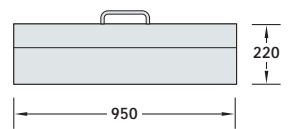

VA 9604
Transport bag
for VA 9523

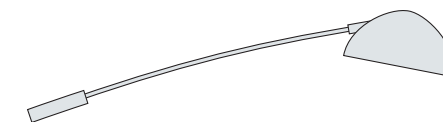

VA 9701
Spotlight, 12V/50W

(without illustration)



VA 8709
Extra bulb
for VA 9701

VA 9009
Extra strip, 30 m
self-adhesive



VA 5019
Connector

Technical information:

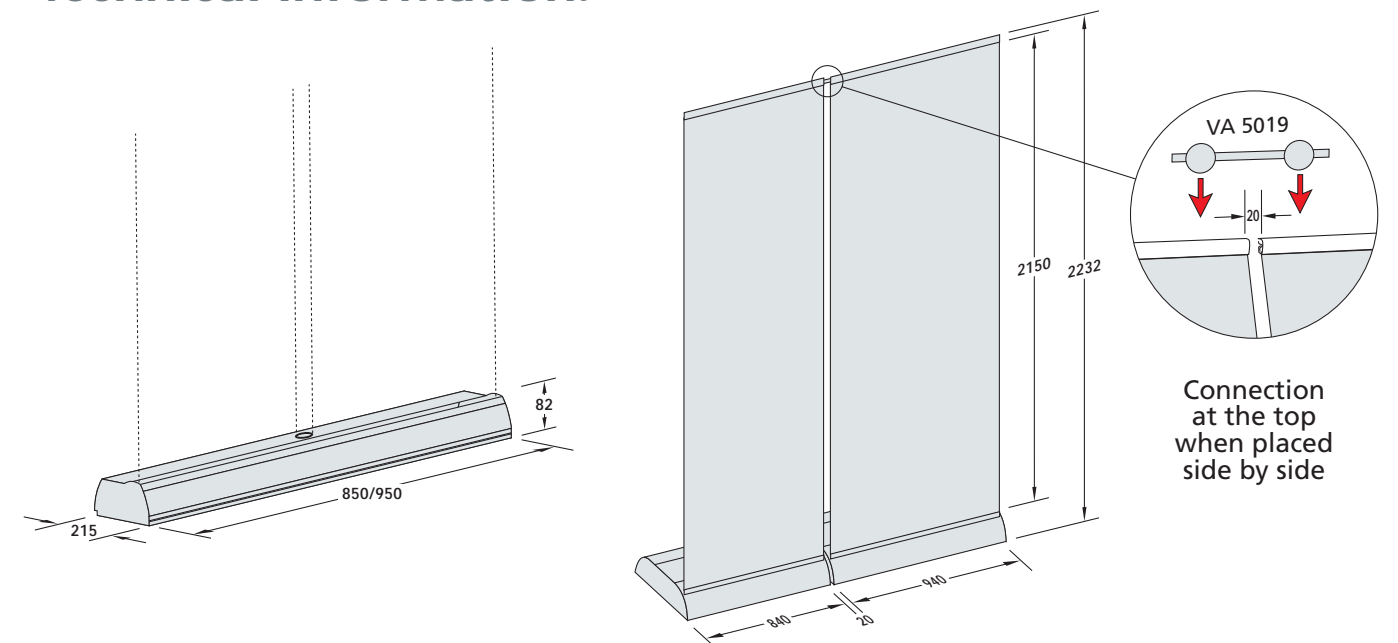

Connection at the top when placed side by side

Promotion Stand

Mobile



The multi-purpose talent. Vertically, horizontally, diagonally – arranged like this, not only diverse information material, but also products, decoration and advertising media can be exposed attractively. The presentation rack is available in two widths, both equipped with lateral elements and horizontal beams, aluminium anodized and wheels (two of the four castors can be locked). With this rack, especially banks and insurance companies have a system at hand that meets their requirements with regard to a clear arrangement of their many products and information material.



Basic modules:

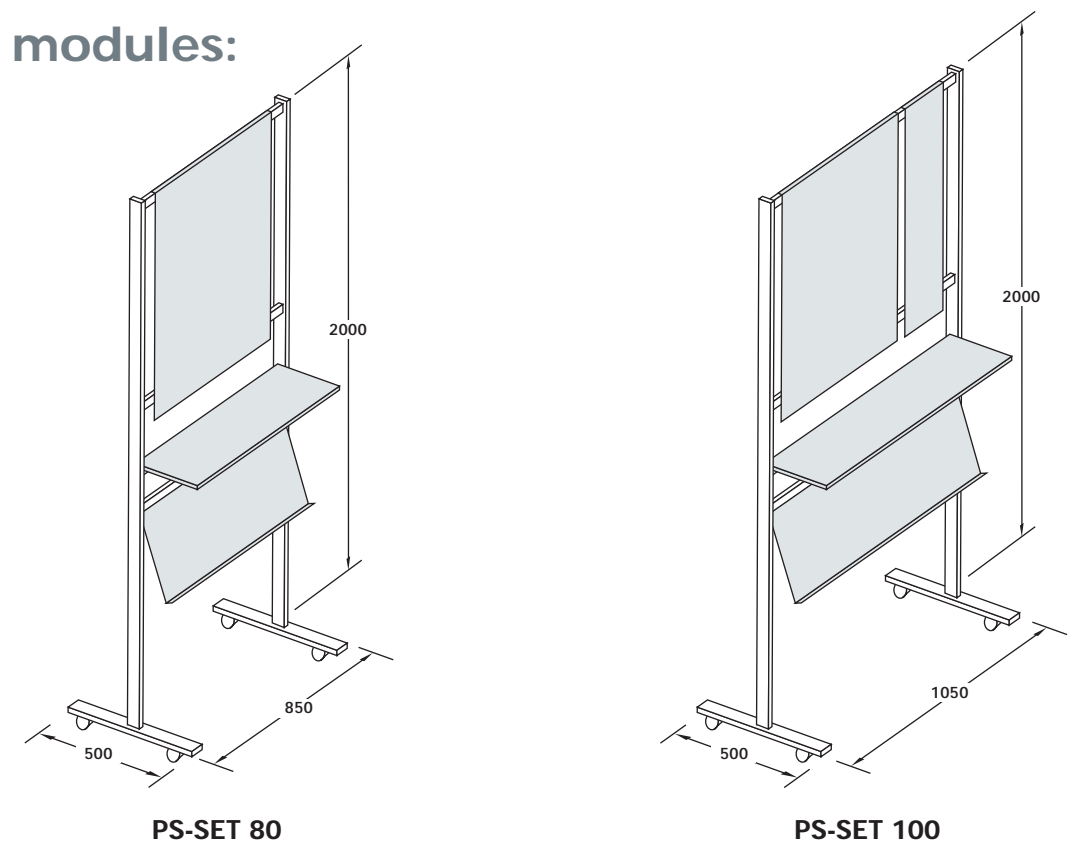

Accessories:

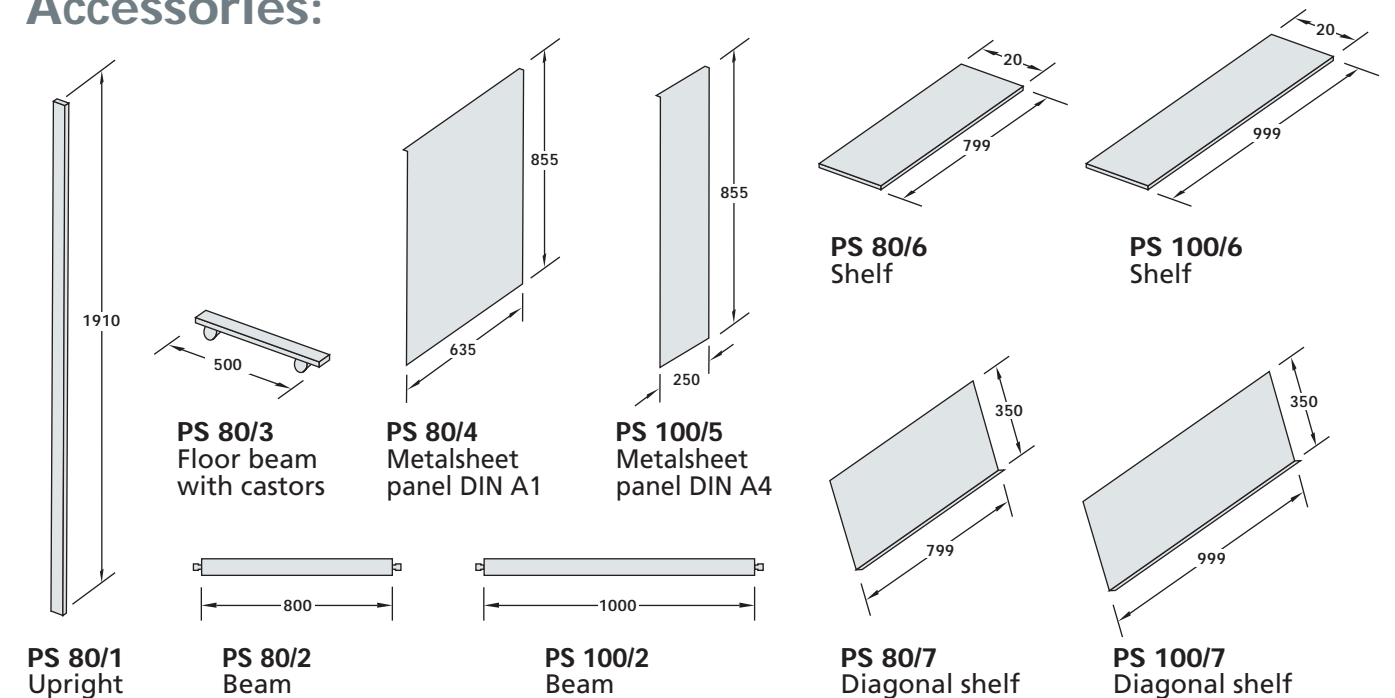

Technical information:

PS-SET 80

h 2000 x w 850 x d 500 mm (exterior dimensions)
Lateral elements and horizontal beams, aluminium anodized
1 metalsheet panel RAL 9006, size DIN A1
1 shelf of aluminium, w 799 x d 200 mm
1 diagonal shelf RAL 9006, w 799 mm
10 magnetics, white

PS-SET 100

h 2000 x w 1050 x d 500 mm (exterior dimensions)
Lateral elements and horizontal beams, aluminium anodized
1 metalsheet panel RAL 9006, size DIN A1
1 metalsheet panel RAL 9006 for 2 placards DIN A4
1 shelf of aluminium, w 999 x d 200 mm
1 diagonal shelf RAL 9006, w 999 mm
10 magnetics, white

OCTAcounter

Display Counter for Exhibitions and Promotions



Model design: Q 400 si

The fastest way to assemble a display counter! With its newly-developed construction system, the new OCTAcounter is impressively simple to erect. The side panels just swivel into position on the front panel - without the need for tools. Its modern design and robust construction allows this counter to be used in a wide variety of ways at exhibitions, marketing events and promotions as well as in offices and shops. Where larger reception counters are needed, OCTAcounter modules can simply be linked together. With worldwide distribution, OCTAcounters can be constructed almost instantly wherever they are wanted.



Model design:
2 pieces Q 400 st, Q 412 st



Swivel technique



Door-Set Q 411 si



Adjustable feet

Basic modules:

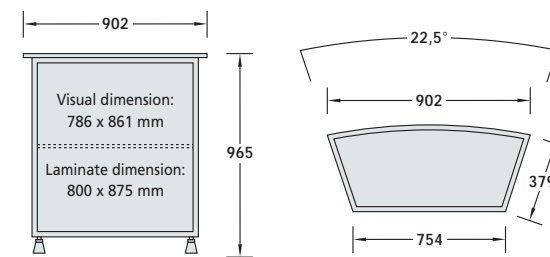

Q 400 st
Basic set, beech finish

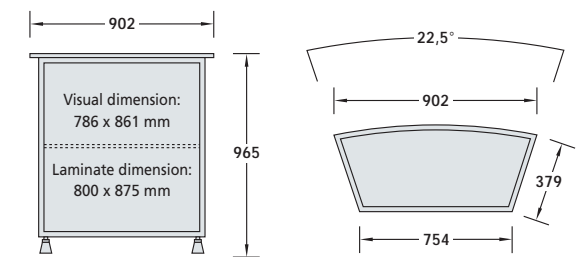

Q 400 si
Basic set, silver-grey RAL 9006

Accessories:

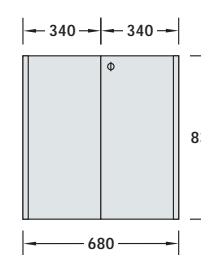

Q 411 st
Door set,
beech finish

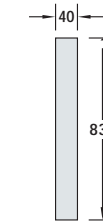

Q 412 st
Connection set,
beech finish

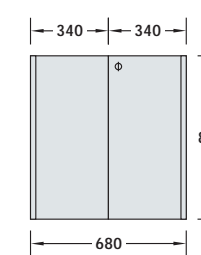

Q 411 si
Door set,
silver-grey
RAL 9006

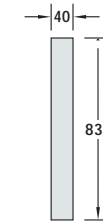

Q 412 si
Connection set,
silver-grey
RAL 9006

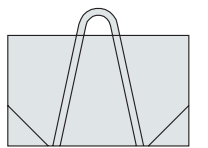

VA 1011
Transport bag
for 1 basic module
including accessories

Technical information:

Additional information:

- Extrusions: Aluminum matt, clear, anodized (silver)
- Counter top: Timber, 16 mm
- Side panels: Timber, 16 mm
- Drawer base: Timber, 16 mm (below and centre)
- Front panel: Timber, 3.2 mm
- Feet: Height adjustable (approx. 10 mm)
- Set of doors: 2 wooden double doors, tool-free assembly lockable, 2 keys

Mounting variants:

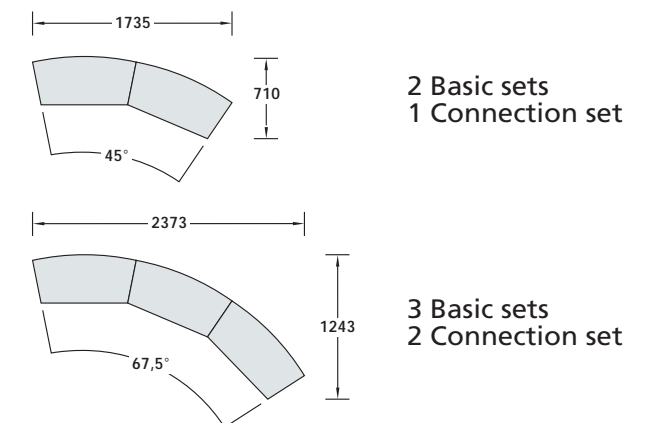

Special designs (like shapes, sizes and surfaces) on request

Transparenta Showcases



Example types: 1 T-5-1930
2 T-1-1500
3 T-1-800

The master of display. In its function as a showcase, TRANSPARENTA's five basic shapes facilitate countless variations, since the basic modules are designed to be combined in any way required. This offers the challenge to design extraordinary display furniture, for safe storage and clear presentation of valuable exhibits. But TRANSPARENTA has even more to offer: glass panels and transparent partitions can be constructed and offer a wide variety of design options, predominantly for trade fair and shop installations. TRANSPARENTA is made from ESG security glass and - thanks to its unique linking design - can be assembled quickly, without needing special tools.



Clear lines

DESIGN
AWARD
WINNER



INDUSTRIE FORUM
DESIGN HANNOVER

The awarded system



Illumination 3x12V/20W

Basic modules:

 rectangular	 T-1-1930 5 shelves, with lighting	 T-1-1850 5 shelves, w/o* lighting	 T-1-1500 4 shelves, w/o* lighting	 T-1-800 2 shelves, w/o* lighting
 trapezoidal	 T-2-1930 5 shelves, with lighting	 T-2-1850 5 shelves, w/o* lighting	 T-2-1500 4 shelves, w/o* lighting	 T-2-800 2 shelves, w/o* lighting
 rectangular	 T-3-1930 5 shelves, with lighting	 T-3-1850 5 shelves, w/o* lighting	 T-3-1500 4 shelves, w/o* lighting	 T-3-800 2 shelves, w/o* lighting
 pentagonal	 T-4-1930 5 shelves, with lighting	 T-4-1850 5 shelves, w/o* lighting	 T-4-1500 4 shelves, w/o* lighting	 T-4-800 2 shelves, w/o* lighting
 square	 T-5-1930 5 shelves, with lighting	 T-5-1850 5 shelves, w/o* lighting	 T-5-1500 4 shelves, w/o* lighting	 T-5-800 2 shelves, w/o* lighting

Accessories

- TST 91-5 Set of sliding door locks for 5 shelves
- TST 91-4 Set of sliding door locks for 4 shelves
- TST 91-2 Set of sliding door locks for 2 shelves
- TST 91 9 Individual sliding door lock

* Showcases without lighting have no plinth and are covered with a glass panel.

Technical information:

- Side panels:** tempered safety glass, 4 mm
- Shelf panels:** base shelf: wood panel, white 6 mm, more tempered safety glass, 4 mm
- Plinth and lighting frame:** steel, powder-coated, light grey
- Lighting:** 3 flush integral spotlights, 12V/20W each with transformer, ready for installation
- Recommended max. load approx. 20 kg

Design Showcases

Square

Clear lines, countless applications. Whether as a showcase with silver-painted wood cover panel, or as a counter with a black wood cover – the basic design remains the same: black plinth base shelf, silver anodized aluminium profiles, side and shelf panels made of tempered safety glass, optional lighting. Quick and easy assembly, which makes the design showcases a versatile accessory at exhibitions, trade fairs and anywhere, where products need to be clearly presented within a sales promotion environment.



Example types: left: DV-10B
right: DV-50B



Example type: DV-30B



Cylinder lock



Optional lighting



Continuously adjustable

Basic modules without lighting:

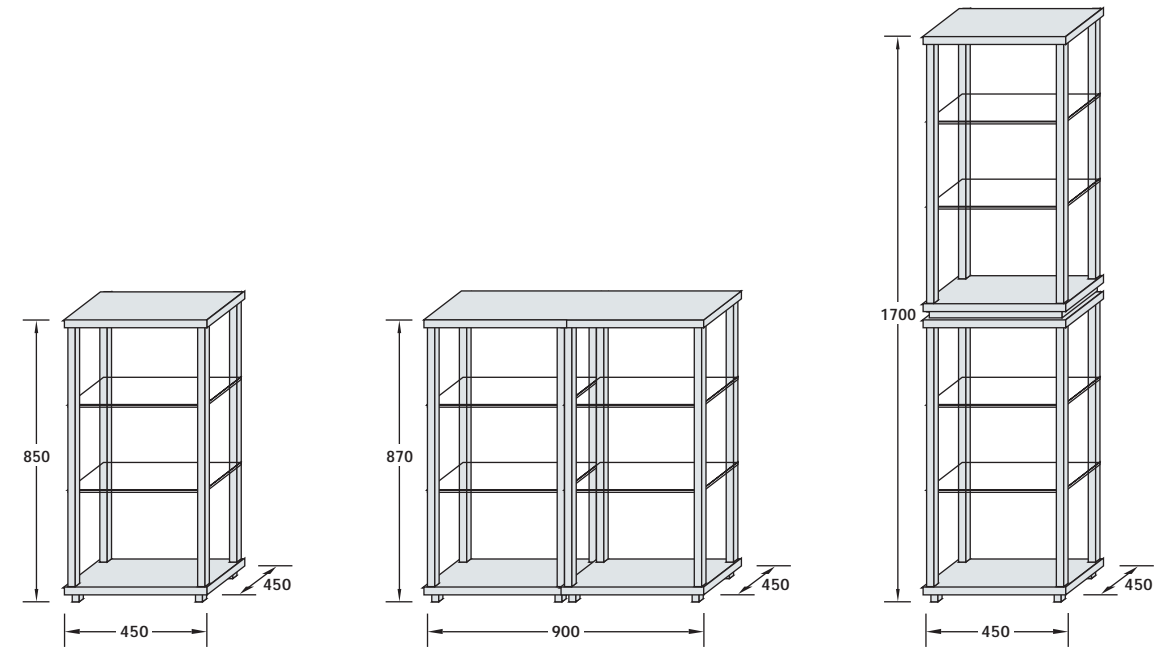

DV-10
Sideboard
silver cover panel

DV-30
Counter
black counter panel

DV-50
Glass showcase
silver cover panel

Basic modules with lighting:

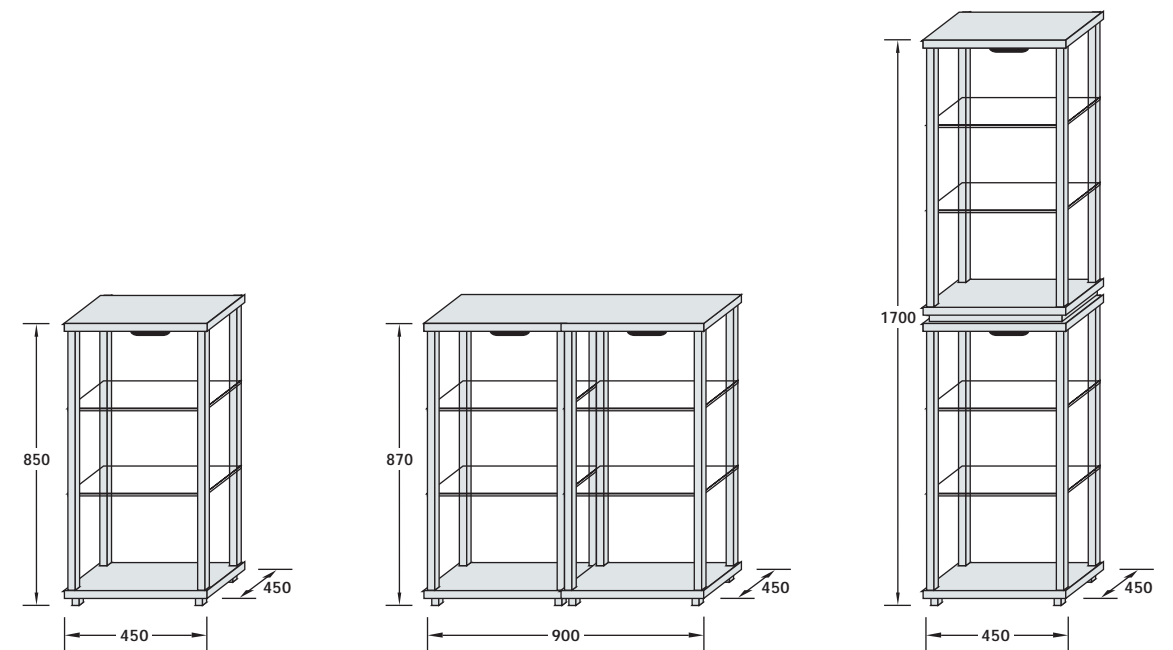

DV-10B
Sideboard
silver cover panel
12V/20W spotlight

DV-30B
Counter
black counter panel
2 12V/20W spotlights

DV-50B
Glass showcase
silver cover panel
2 12V/20W spotlights

Wall and Counter Showcases

Square and Quarter-round Profile



Example type: TM-Set 31

Additional points of sale or eye-catchers for interior applications: the lockable wall and counter showcases facilitate a safe, effective and elegant presentation of products or collections. The design offers two options: tower format with hinged doors or sideboard format with sliding doors. All models are furnished with high-quality aluminium profiles, glass doors, glass side panels and adjustable shelves made of tempered safety glass. One intelligent detail: the magnetic back panel (incl. 8 white magnets) offers space for price, product or other information.

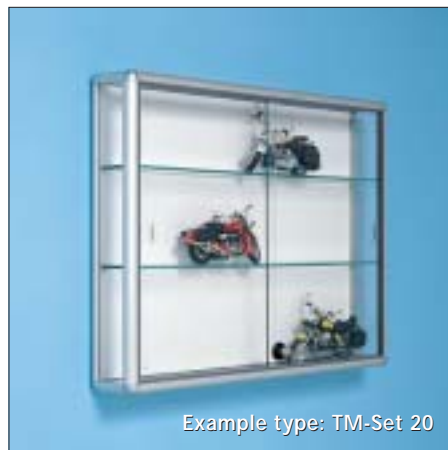

Example type: TM-Set 20



TM-Set 11



TM-Set 10



TM-Set 65

Basic modules - Quarter-round profile:

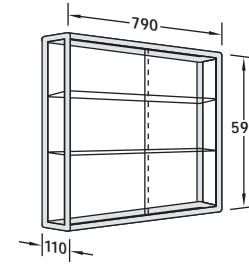

TM-Set 20
Wall showcase with sliding door, 1 white wood base shelf, 2 glass shelves 6 mm, silver anodized profile

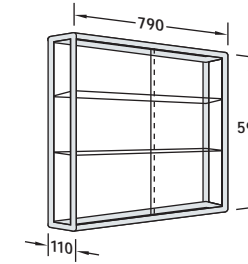

TM-Set 30
Wall showcase with sliding door, 1 white wood base shelf, 2 glass shelves 6 mm, high-polish chrome-plated profile

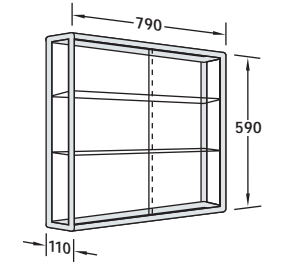

TM-Set 40
Wall showcase with sliding door, 1 white wood base shelf, 2 glass shelves 6 mm, black anodized profile

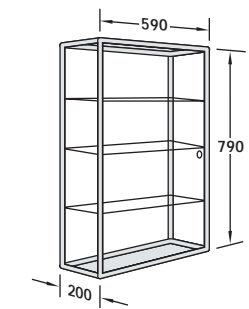

TM-Set 21
Wall showcase with hinged door, 1 white wood base shelf, 3 glass shelves 6 mm, silver anodized profile

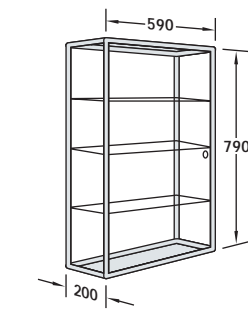

TM-Set 31
Wall showcase with hinged door, 1 white wood base shelf, 3 glass shelves 6 mm, high-polish chrome-plated profile

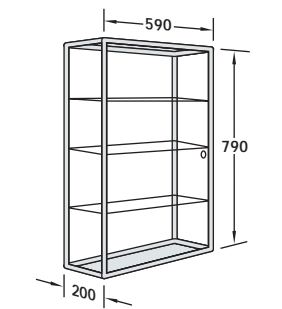

TM-Set 41
Wall showcase with hinged door, 1 white wood base shelf, 3 glass shelves 6 mm, black anodized profile

Basic modules - Square profile:

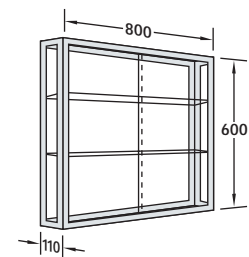

TM-Set 10
Wall showcase with sliding door, 1 white wood base shelf, 2 glass shelves 6 mm, white profile RAL 9010 powder-coated

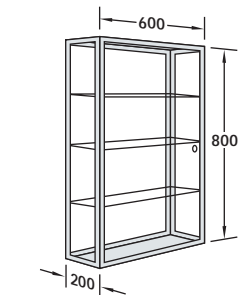

TM-Set 11
Wall showcase with hinged door, 1 white wood base shelf, 3 glass shelves 6 mm, white profile RAL 9010 powder-coated

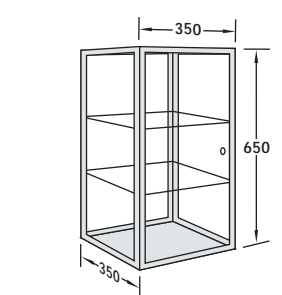

TM-Set 65
Counter showcase with hinged door, 1 white wood base shelf, 2 glass shelves 4 mm, silver anodized profile

Literature Rack

Brochure Display

Attractive design and a great variety of presentation possibilities. With just two basic systems, brochures or documents of the standard size A4 can be arranged clearly in many different ways. One above the other or side by side, parallel or in a zigzag line, fixed or mobile (with two lockable castors). All literature racks and brochure shelves are made of silver-anodized aluminium profiles with pockets or shelves of transparent acrylic glass.



Example type: P-8 D



Example type: P-ZZ 6



Example types: P-3, P-1, P-2



Example types: VA 1110, VA 1111



VA 1110



VA 8607

Basic modules - Literature racks:

Frames made of silver-anodized aluminium, shelves of acrylic glass

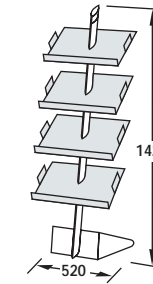

P-8 D
8 DIN A4-shelves

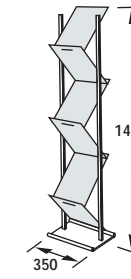

P-ZZ 6
6 DIN A4-shelves

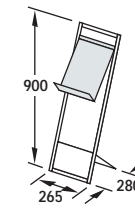

P-1
1 DIN A4-shelves

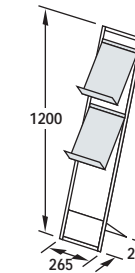

P-2
2 DIN A4-shelves

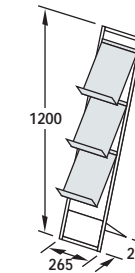

P-3
3 DIN A4-shelves

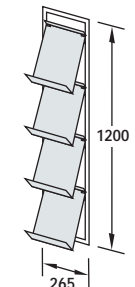

P-4 W
4 DIN A4-shelves

Basic Modules - Brochure display:

Extrusions: Aluminium, silver anodised,
Brochure bags: Nylon

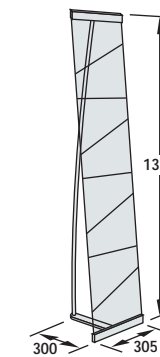

VA 1110
Literature rack
4 sections

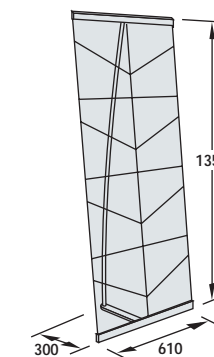

VA 1111
Literature rack
8 sections

Accessories - Brochure display:

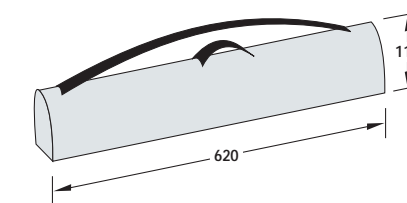

VA 8607
Transport bag

Brochure Shelves

Brochure Shelves "Light"

The objective of these stable literature racks is to present prospective literature in DIN A-4 format in a clearly arranged way. The racks consist of silver-anodised aluminium profiles. The shelves are made of transparent acrylic glass which is always aesthetically pleasing. All movable literature racks are equipped with two lockable castors. The "light series" is not equipped with castors and therefore cannot be moved. The top plate allows additional and individual advertising messages to be conveyed.



Example type: P-12

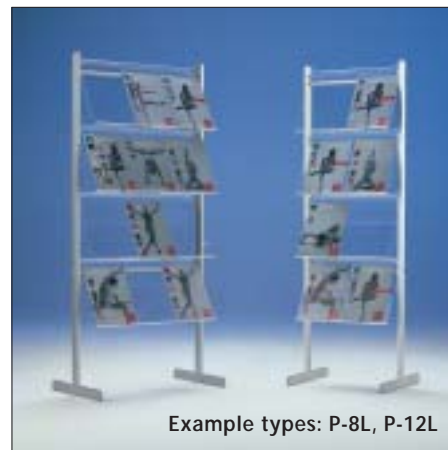

Example types: P-8L, P-12L



Movable with castors



Compartments



Example type: P-12 T

Basic modules - Brochure shelves:

Stable constructions made of silver-anodized aluminium profiles, compartments of acrylic glass, mobile, 2 lockable castors

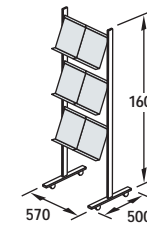

P-6
6 DIN A4-shelves

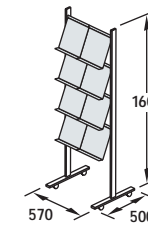

P-8
8 DIN A4-shelves

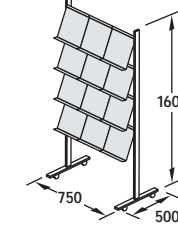

P-12
12 DIN A4-shelves

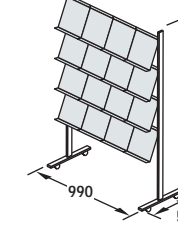

P-16
16 DIN A4-shelves

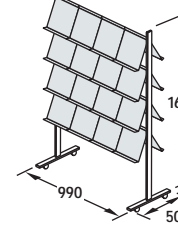

P-32
32 DIN A4-shelves

Basic modules - Brochure shelves with top plate:

Stable constructions made of silver-anodized aluminium profiles, compartments of acrylic glass, mobile, 2 lockable castors, inclusive top plate

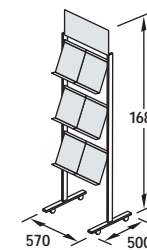

P-6 T
6 DIN A4-shelves
+ top plate

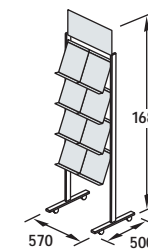

P-8 T
8 DIN A4-shelves
+ top plate

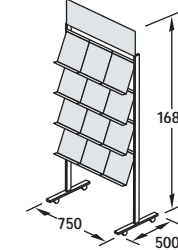

P-12 T
12 DIN A4-shelves
+ top plate

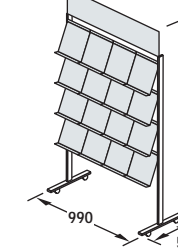

P-16 T
16 DIN A4-shelves
+ top plate

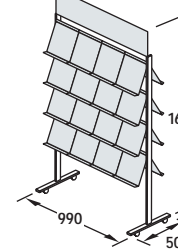

P-32 T
32 DIN A4-shelves
+ top plate

Basic modules - Brochure shelves „Light“:

Stable constructions made of silver-anodized aluminium profiles, compartments of acrylic glass

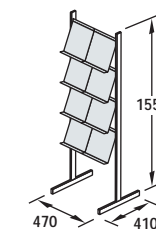

P-8L
8 DIN A4-shelves

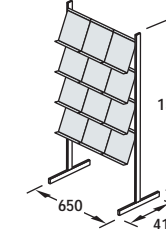

P-12L
12 DIN A4-shelves

Display Easel

Hinged Display Frame



Example type: T-AS 1, T-Z 1, T-Z 2

Active selling aids that cannot be ignored. The first one is a placard rack for placards and posters of the size A1 made of high-quality silver-anodized aluminium profiles. Suitable for interior and exterior areas. Equipped with a tie bar attachable at the top, two alternate frames with protective antireflex foil and brochure basket for additional information material.

The second one is a hinged display frame in 5 sizes (from A4 to A0) made of high-quality aluminium profiles for a perfect presentation and a quick modification without much effort.



Example type: T-A A1



T-Z 2



T-Z 1



Replacement of placards in just a few seconds (UV protective foil T-Z 3)

Basic module - Display easel:

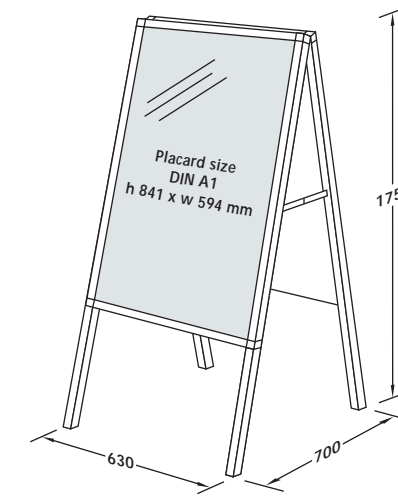

T-AS 1
Equipped with 2 alternate frames

Accessories - Display easel:

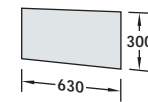

T-Z 2
Advertising panel, white, attachable



T-Z 1
Brochure basket black



T-Z 3
Replacement UV protective foil DIN A1

Basic modules - Hinged display frame:

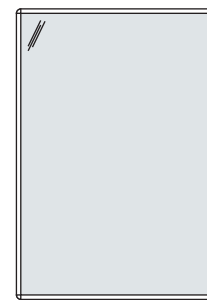

T-A A0
841x1189 mm

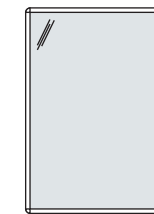

T-A A1
594x841 mm

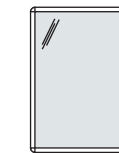

T-A A2
420x594 mm

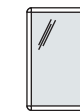

T-A A3
297x420 mm



T-A A4
210x297 mm

Dimensions according to the placard size

Technical information - Hinged display frame:

High-quality aluminium profiles, 28 mm
Replacement of placards in a few seconds
Stable back
Self-adhesive and additionally equipped with fixing materials
Suitable for exterior areas

Illumination Box

Indoor



Example type: T-L 1
Panel recommendation: paper placards of the standard size DIN A1

Showing advertising messages in a favorable light. With these systems, placards of the standard size DIN A1 get the attention they deserve. The illuminated showcase with a polystyrene casing and a hinged display frame made of aluminium has been designed exclusively for indoor applications. It is simply screwed to a wall and illuminated via a cable of 2 m equipped with a switch. Due to the alternate hinged display frame, advertising messages, which are presented effectively behind the transparent protective foil, can be updated quickly.

Basic module:

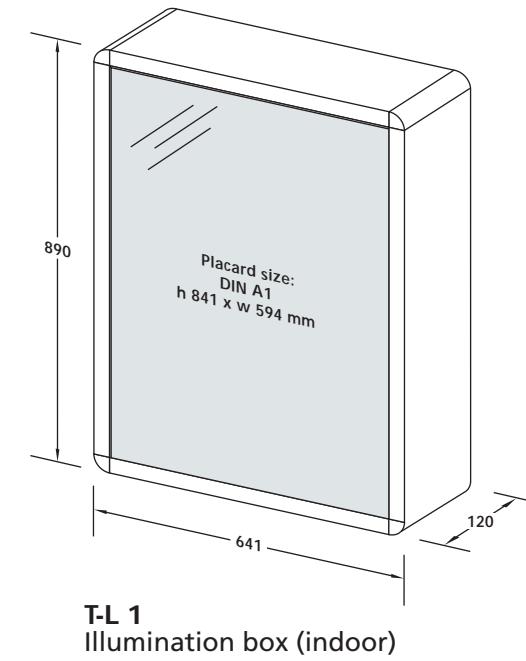

T-L 1
Illumination box (indoor)

Accessories:



T-Z 3
UV protective foil
DIN A1 for replacement

Fixing materials
Screws and dowels are included

Technical information:

Integrated illumination:	4 x 11 Watt
Standard placard size:	DIN A1
Casing:	Polystyrene
Hinged display frame:	Aluminium, silver-anodized, 28 mm
Protective foil:	0.75 mm, transparent
Cable:	2 m with switch
Weight:	9.8 kg

The illumination box can either be mounted vertically or horizontally (see example)

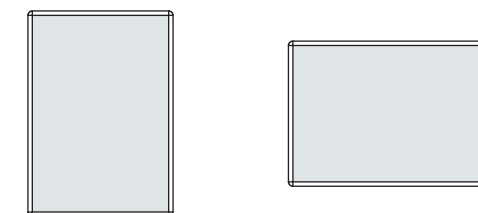

High-polish chrome-plated corners



Clip profile



Integrated illumination

Clothes Racks

Wall-mounted Clothes Rack



Example type: TG-SET 1, TG-SET 3

These “business cards” in the entrance area have two important functions: combining an aesthetic look with clearly laid-out storage concepts. The wall-mounted silver anodized aluminium clothes rack is characterized by its straight lines – and its versatility: the clothes rod can be installed at any desired height, thus it can also be used as a children’s clothes rack. The two glass shelves “Mastercarrée” offer plenty of space for shoes, hats, scarves etc.

Mobile clothes rack

The perfect clothes rack for events, restaurants, hotels, pubs etc. The mobile clothes rack with its silver anodized aluminium profiles and the double-fronted crown has 4 sturdy castors, 2 of which can be locked, which makes it versatile and mobile. It also offers a maximum of clothes storage capacity, taking up a minimum of space: 46 hooks and optional umbrella storage incl. drip tray. Thus, the mobile clothes rack has everything that is needed – with the added extra of attractive design.



46 hooks in total



2 lockable castors



Example type: TG-SET 11

Basic modules - Wall-mounted clothes rack

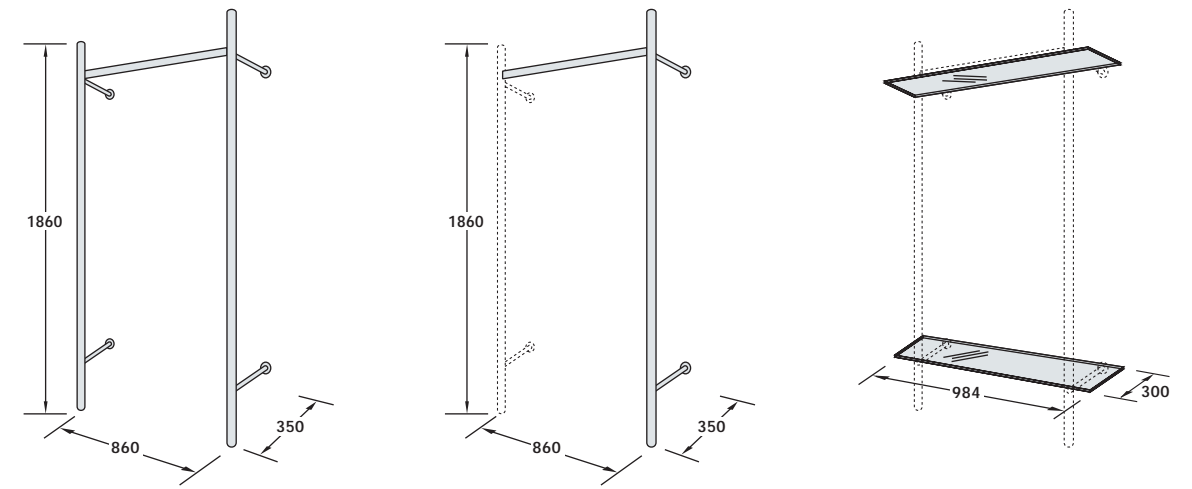

TG-SET 1
Basic frame

TG-SET 2
Extension frame

TG-SET 3
2 glass shelves
“Mastercarrée”
for hat and shoe
storage, 8 mm

Basic modules - Mobile clothes rack:

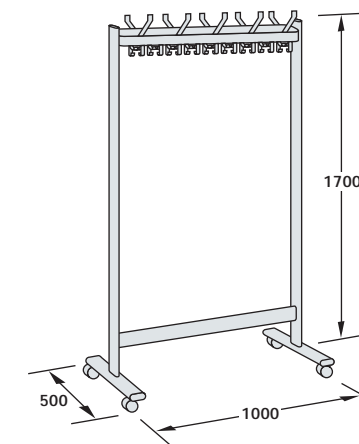

TG-SET 10
Mobile clothes rack
w/o umbrella storage

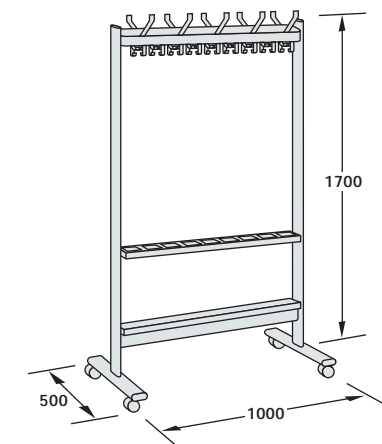

TG-SET 11
Mobile clothes rack
with umbrella storage

Twin-Set Shelving System



Example type: TW 108, TW 208

The aesthetic alternative to traditional shelving: aluminium wall extrusions plus shelves made of safety glass or wood. These work together to produce shelving solutions that appear weightless, almost as if suspended in the air. This type of storage or display provides entirely new opportunities for individual wall display designs. The aluminium extrusion is assembled quickly and easily. Then the shelf slides in easily. Additional practical benefit: the extrusion profile has two hooks to allow suspension of mirrors or pictures.



Hooks to suspend pictures



Wooden shelf, 16 mm



Tempered safety glass shelf, 8mm

Basic modules - Wall profiles:



TW 106 Wall extrusion*
60 cm wide,
incl. end caps,
2 hooks and
fittings



TW 108 Wall extrusion*
80 cm wide,
incl. end caps,
2 hooks and
fittings

* The wall extrusions are manufactured to fit with 8mm glass or 16mm wood shelves.

Basic modules - Shelves:



TW 206
Tempered safety glass shelf, 8 mm
60 cm wide
20 cm deep



TW 306
Tempered safety glass shelf, 8 mm
60 cm wide
30 cm deep



TW 208
Tempered safety glass shelf, 8 mm
80 cm wide
20 cm deep



TW 308
Tempered safety glass shelf, 8 mm
80 cm wide
30 cm deep

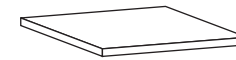

TW 360
Wood shelf, 16 mm white
60 cm wide
30 cm deep



TW 360
Wood shelf, 16 mm white
80 cm wide
30 cm deep



TW 361
Wood shelf, 16 mm black
60 cm wide
30 cm deep



TW 381
Wood shelf, 16 mm black
80 cm wide
30 cm deep

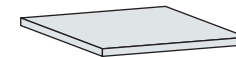

TW 362
Wood shelf, 16 mm beech
60 cm wide
30 cm deep



TW 382
Wood shelf, 16 mm beech
80 cm wide
30 cm deep

Each package contains 3 shelves (all articles).