

OCTAquick...
 ...a quick and
 simple way to
 build exhibition
 stands!



© OCTANORM®-Vertriebs-GmbH, Germany (1605-04/2003)

A build-it-yourself portable exhibition stand

Product catalogue



OCTAquick

OCTANORM®-Vertriebs-GmbH
 Raiffeisenstrasse 39
 D-70794 Filderstadt
 Tel. (+49) 711 / 77003-0
 Fax (+49) 711 / 77003-53
 e-mail: info@octanorm.de
 http://www.octanorm.de



OCTANORM®

Expertise with Creative Systems



OCTANORM®

Expertise with Creative Systems

OCTAquick

Exhibiting has never been easier or more cost-effective...



Participating in exhibitions requires an investment of both time and money. New OCTAquick has been purpose-designed to help you achieve maximum benefit with minimum commitment to the time and cost required to build and dismantle stands.

OCTAquick is a new portable exhibition stand system that fits into the back of an estate car and can be assembled in minutes by unskilled personnel. The system comprises four basic modules for the construction of displays that range from

a simple panel wall to a medium sized exhibition stand, each set of components being complete with three spotlights and a power cable. With OCTAquick's high quality components and stylish design, your self-build stand has a truly professional appearance to help you achieve optimum impact and effectiveness. And you have complete control over construction and dismantling.

OCTAquick »3x3«

The module for maximum impact



Example types: Q 40, Q 41

A full 9 square metres of exhibition space constructed in minutes from components transported in 2 carry cases in the back of your estate car – that's the OCTAquick »3x3« module. Beams and poles fit together quickly and simply - the secret is the OCTANORM joint with its easy to use tension lock. Print your graphics onto fabric banners that are suspended from the beams by means of clips. Alternatively, use solid infill panels, which can also be fitted into the beams. Components, including three 150-watt spotlights and a power cable, are positioned in the carry case, whilst the case itself has castors for ease of transportation. Accessories include counters, display cases and literature racks (see pages 14-15) to help you get the most from your stand space.

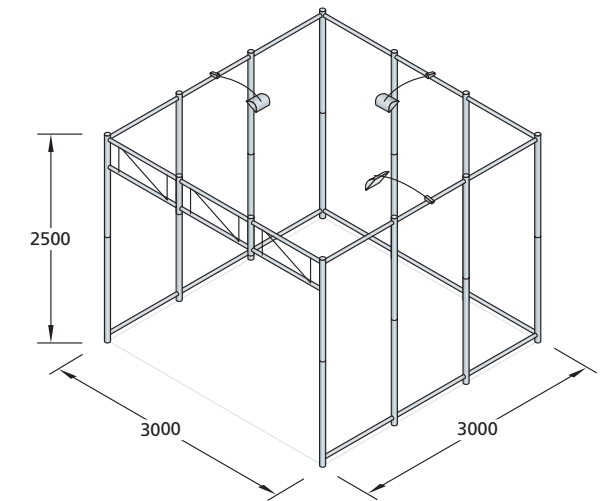

Q 40
Construction set
including transport case and lighting

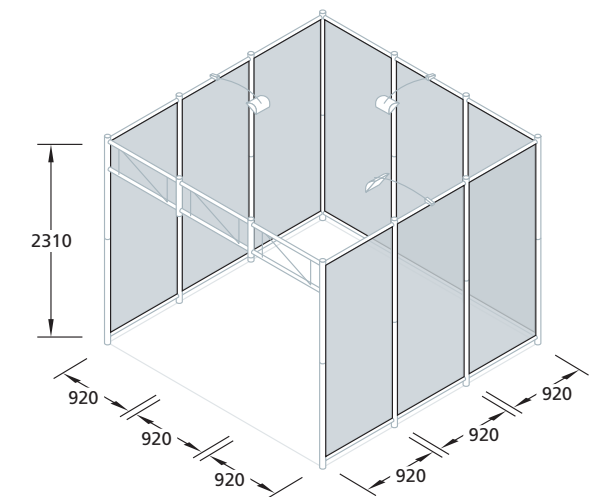

Q 41
Wall infill panel set »fabric«, white,
with inserted mounting profile

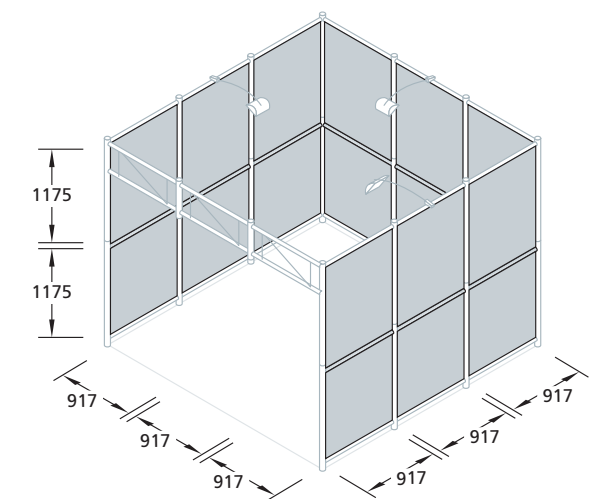

Q 42
Wall infill panel set »wood«, white, 3.2 mm
including 9 beams



Sturdy transport case



Easy and precise assembly



Trusted OCTANORM
tension lock joint



Suspending the fabric panel

OCTAquick »3x2«

Combining impact and economy



Example types: Q 30, Q 31

Where space is less readily available, the OCTAquick »3x2« module enables impact to be combined with economy. It uses the same high quality components – beams, poles and infill panels – to create 6 square metres of useable exhibition space. Again graphics can be printed onto fabric banners and suspended from beams. If solid infill panels are used, shelves can be fitted as optional extras to create more display area. The basic metalwork together with three 150-watt spotlights are housed in two robust carry cases fitted with castors for ease of handling. The system is very stable when erected and does not depend on infill panels for its structural integrity. Accessories include counters, display cases and literature racks (see pages 14-15) to help you get the most from your stand space.

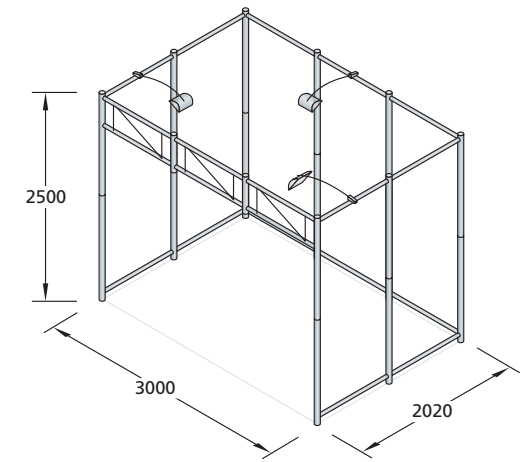

Q 30
Construction set
including transport case and lighting

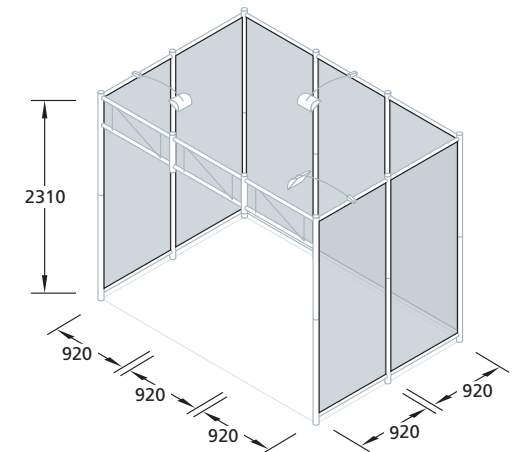

Q 31
Wall infill panel set »fabric«, white,
with inserted mounting profile

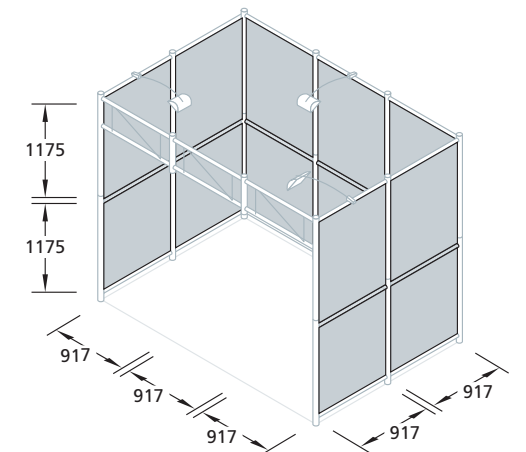

Q 32
Wall infill panel set »wood«, white, 3.2 mm
including 7 beams



Q 370 spotlight



Shelf set Q 80



Wall infill panels



Height-adjustable foot

OCTAquick »3x1«

Effective display in a compact area



Example types: Q 20, Q 21

Where exhibition space is at a premium, the OCTAquick »3x1« module enables effective displays to be mounted in the most compact area. The assembled components create 3 square metres of useable exhibition space. For companies operating on a divisional basis or where topical information needs to be frequently updated, printed fabric banners can be used to form a constant background with framed graphic panels employed to present current information. All metalwork components, including three 150-watt spotlights, are housed in two carry cases ready for quick and easy erection. Accessories include counters, display cases and literature racks (see pages 14-15) to help you get the most from your stand space.

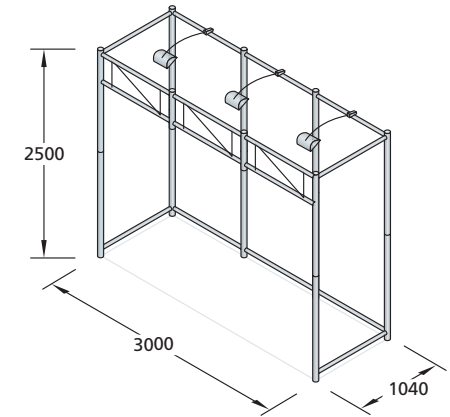

Q 20
Construction set including transport case and lighting

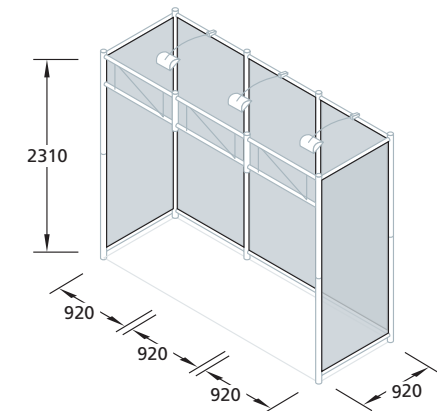

Q 21
Wall infill panel set »fabric«, white, with inserted mounting profile

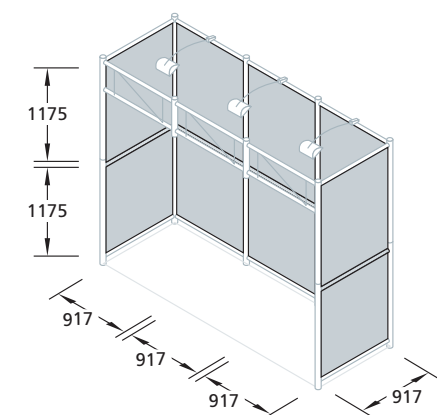

Q 22
Wall infill panel set »wood«, white, 3.2 mm including 5 beams



Suspension of wire rope poster frame set Q 90

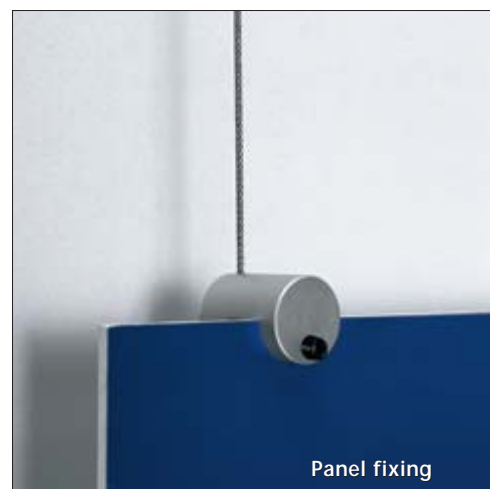

Panel fixing



Truss beam design



Simple cable layout

OCTAquick »Wall«

Panel display »starter-pack«



OCTAquick's Q10 module is a panel display system with the potential to become an exhibition stand. Using OCTAquick beams and poles it provides 3 linear metres of panel display area and is supplied complete with three 150-watt spotlights and a power cable. Infill panels can be fabric or solid with graphics applied as required. Q10 modules can be used individually or in combination, or integrated with other OCTAquick modules to form exhibition stands. Accessories include a panel-mounted literature holder and a free-standing literature rack (see pages 14-15).

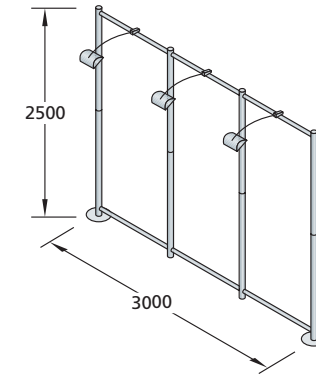

Q 10
Construction set including cardboard box and lighting

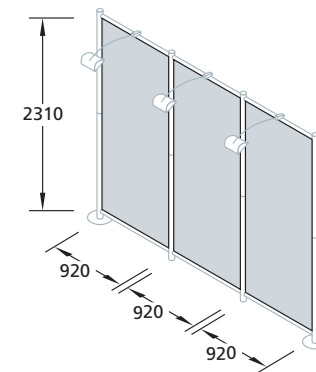

Q 11
Wall infill panel set »fabric«, white, with inserted mounting profile

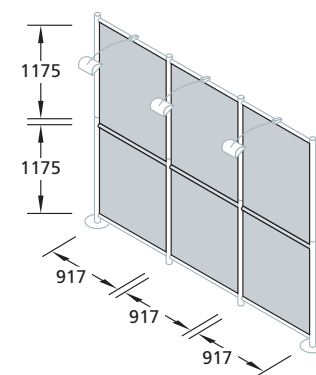

Q 12
Wall infill panel set »wood«, white, 3.2 mm including 3 beams



Stylish round profiles



Literature holder set O 81



Separately installable lighting

OCTAquick »1x3«

The Extension Module

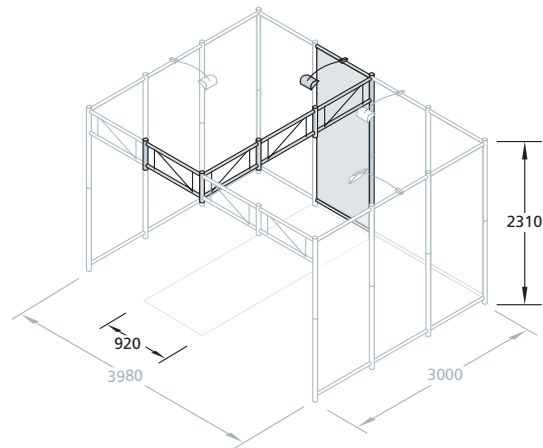

Stand size
»4x3«*

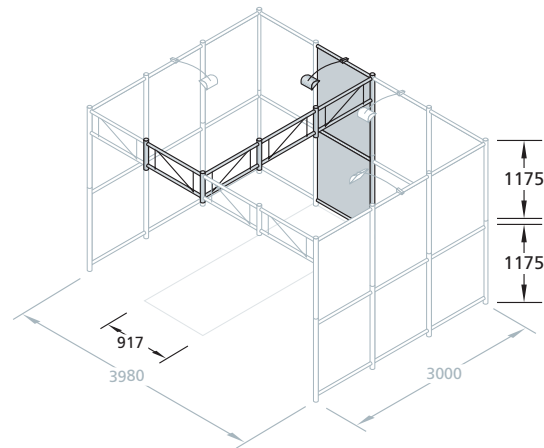

Q 40+Q 41 (already available)
Q 50 1x3 Extension set
incl. transport case and lighting
Q 51 Wall infill panel set »fabric«, white,
with inserted mounting profile

Q 40+Q 42 (already available)
Q 50 1x3 Extension set
incl. transport case and lighting
Q 52 Wall infill panel set »wood«, white, 3.2 mm
incl. 1 beam

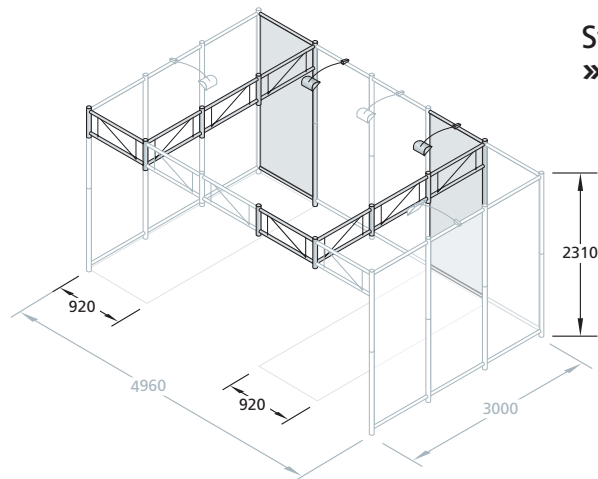

Stand size
»5x3«*

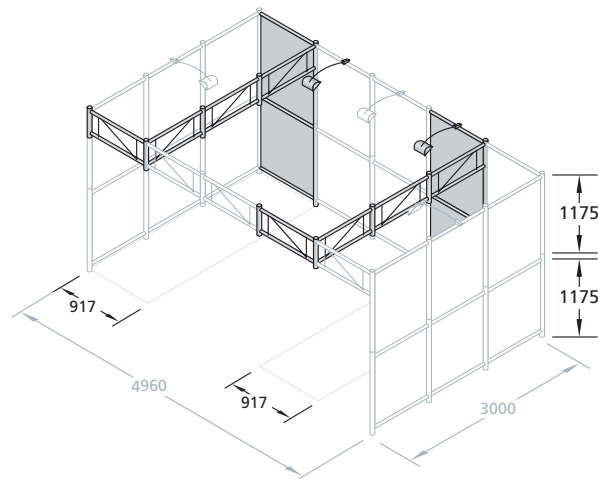

Q 40+Q 41 (already available)
2x Q 50 1x3 Extension set
incl. transport case and lighting
2x Q 51 Wall infill panel set »fabric«, white,
with inserted mounting profile

Q 40+Q 42 (already available)
2x Q 50 1x3 Extension set
incl. transport case and lighting
2x Q 52 Wall infill panel set »wood«, white, 3.2 mm
incl. 1 beam

Basic OCTAquick exhibition stand modules can be expanded simply and easily with a purpose designed extension module illustrated above. The extension module is supplied in its own carry case complete with a 150-watt spotlight and power cable. The OCTAquick accessories range has

been carefully formulated to provide optional extras that will help to maximise the use of exhibition space. The result is a range of unique self-build modules and accessories for the effective presentation of a company, its products and services. Exhibiting has never been so easy or cost-effective.

OCTAquick

Technical information »infill panels«

Wall infill panel »fabric«

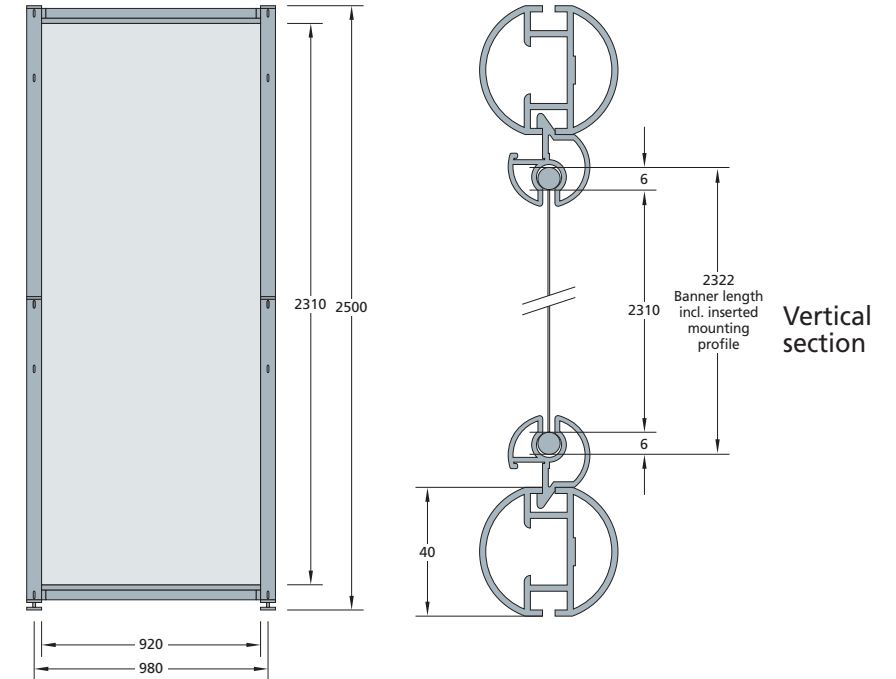

Wall infill panel »wood«

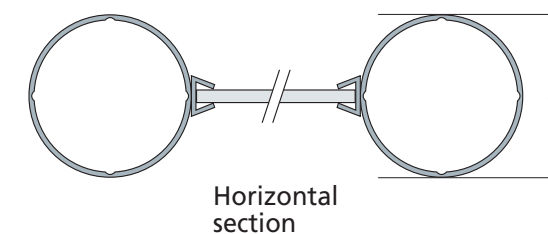
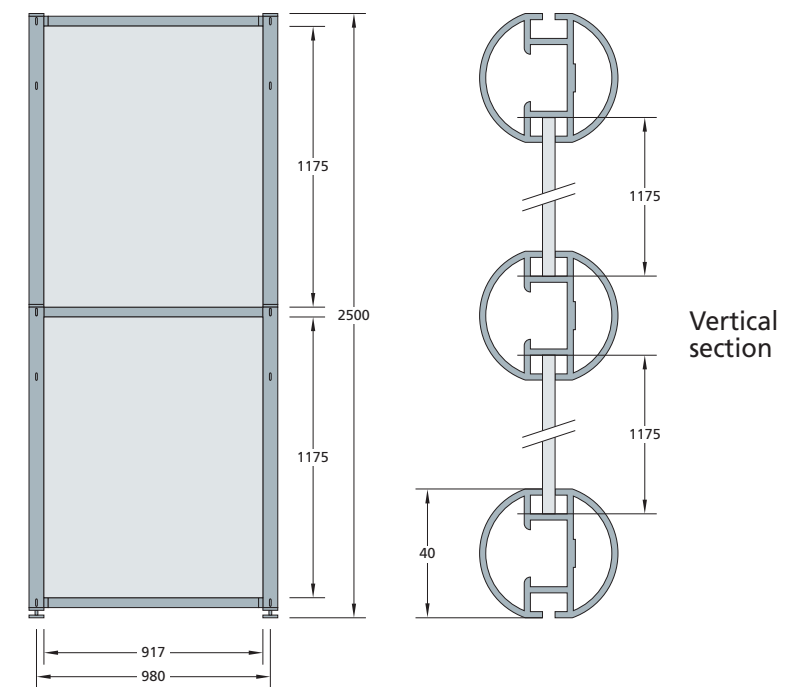

OCTAquick

Accessories/optional extras

Standard accessories: (included in the sets)

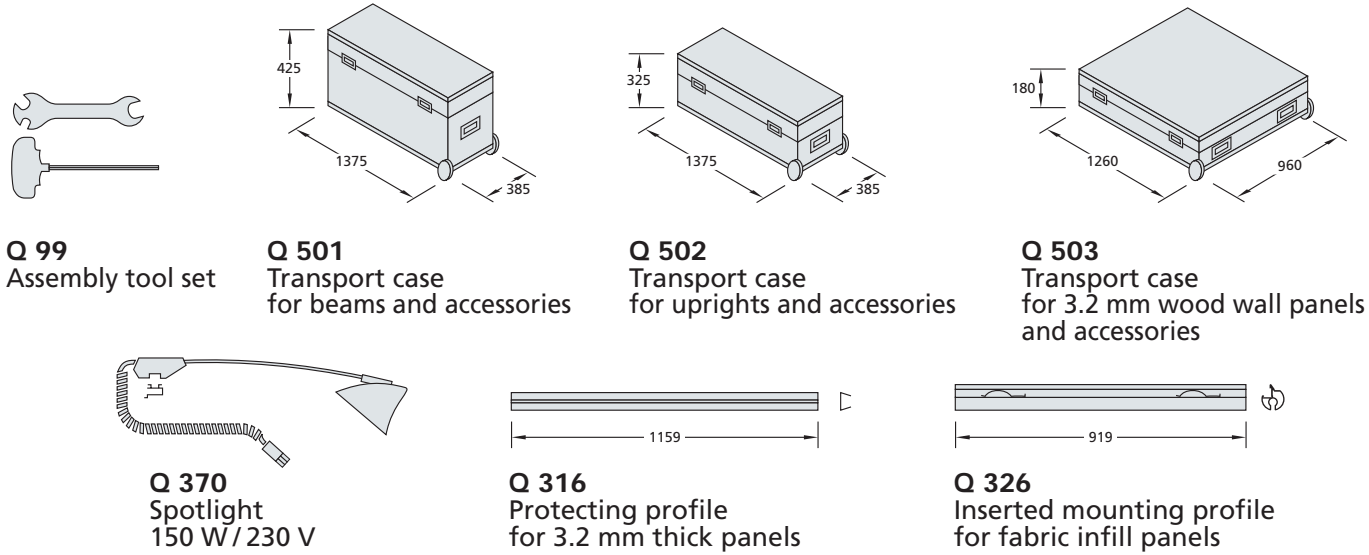

Optional extras:

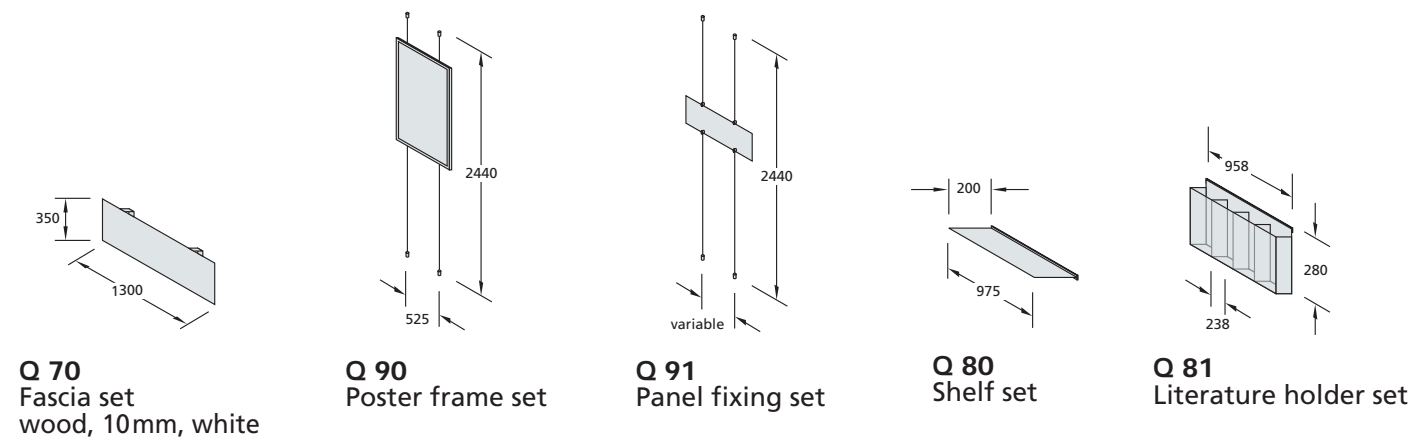

Accessories:

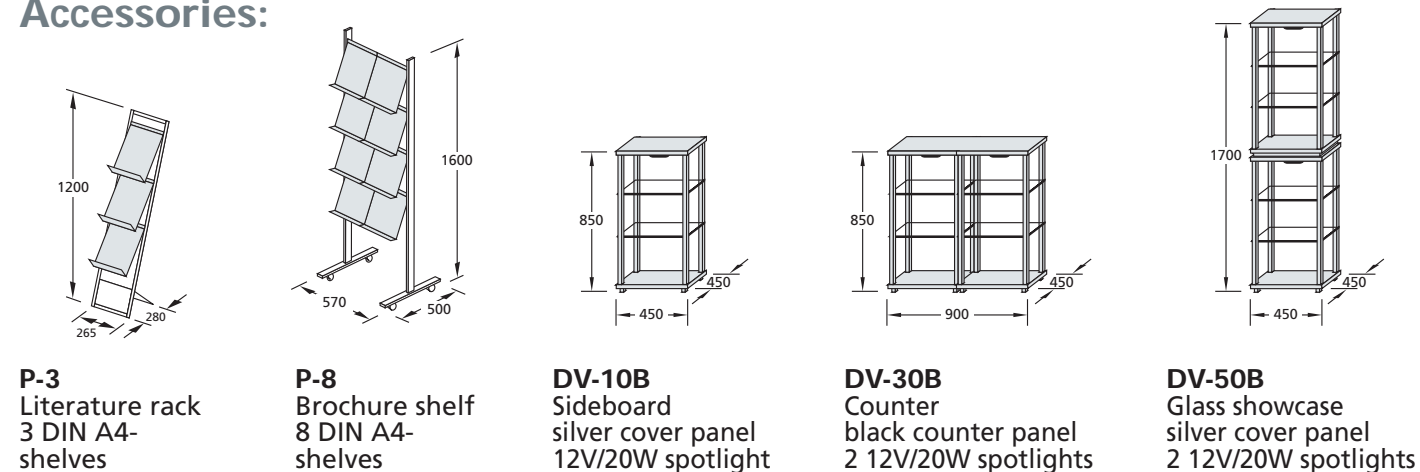

OCTAcounter

Trade fair and promotion counter



Model design: Q 400 st



Model design: Q 400 si

Basic module:

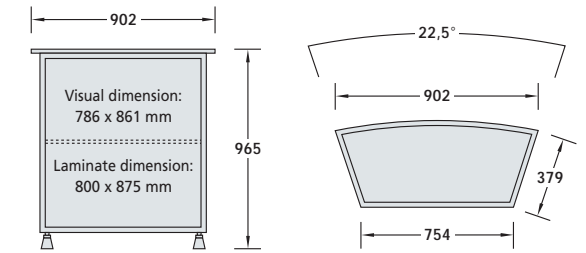

Q 400 st
Basic set, beech finish

Q 400 si
Basic set, silver-grey RAL 9006

Accessories:

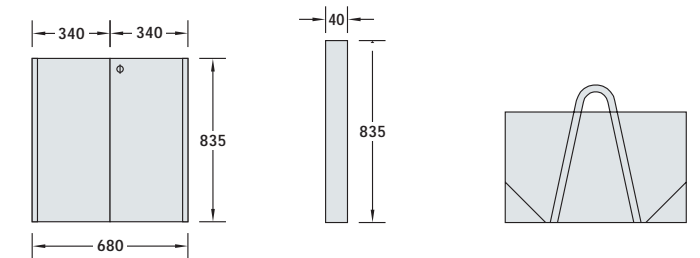

Q 411 st
Door set,
beech finish

Q 412 st
Connection set,
beech finish

VA 1011
Transport bag
for 1 basic
module
including
accessories

Q 411 si
Door set,
silver-grey
RAL 9006

Q 412 si
Connection set,
silver-grey
RAL 9006

Technical information:

Additional information:

- Extrusions: Aluminium, matt clear anodized, silver
- Counter top: Wood, 16 mm
- Side panels: Wood, 16 mm
- Drawer base: Wood, 16 mm (below and centre)
- Front panel: Wood, 3.2 mm
- Feet: Height adjustable (approx. 10 mm)
- Set of doors: 2 wooden double doors, tool-free assembly lockable, 2 keys

Special designs (like shapes, sizes and surfaces) on request

Extension modules:

